

MULTI-COMPONENTS

IEC electric motor range from size 132 up to size 355



Bell-housings & Couplings sizing

	p.
AUTOMATIC	11
MANUALLY	12

SOFTWARE FOR AUTOMATIC CALCULATION

The web-based software program will allow you to select the most suitable MP Filtri's Filters, in accordance with your process design requirements.

The program will automatically check your input design process prior to propose you the acceptable solutions and create an output in PDF report style format.

The MP Filtri Selection Tool software program is easy to use with a flexible fast design method and provides improved layout formats with full descriptions.

The web-based tool is available at MP Filtri website at following link:
<https://www.mpfiltri.com/tools/>

The related, complete user guide is available as Manual and downloadable from the "Download" section of MP Filtri website, as well as scanning the following QR code



Scan or click me!



**BELL-HOUSINGS
& COUPLINGS**





BELL-HOUSINGS & COUPLINGS SIZING

A GUIDE TO SELECT THE CORRECT BELL-HOUSING AND DRIVE COUPLING MANUALLY

DATA REQUIRED

- Electric motor power/motor size
- Manufacturer and pump type

TO VERIFY:

- 1 - Pump and motor shaft dimensions (see electric motor data sheet)
- 2 - Shaft and flange pump (see pump data sheet)

Example:

- Electric motor 2.2 kW - size 100-112
- Atos pump code PFE31 - Shaft 1

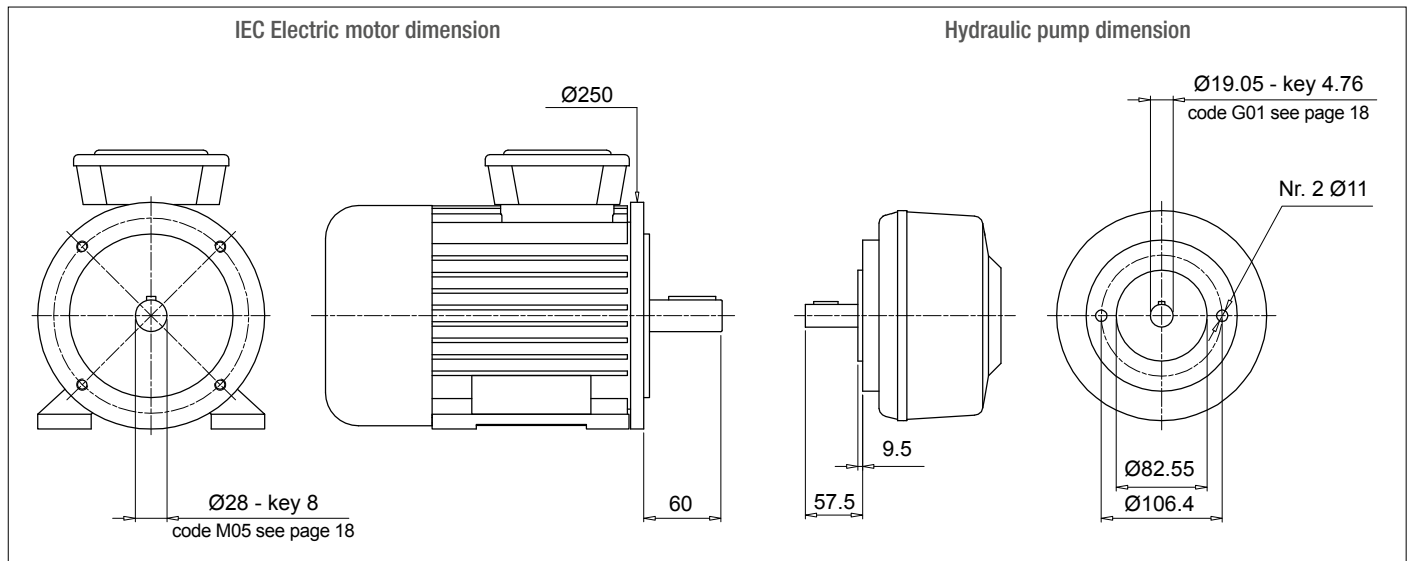

Bell-Housing's length calculation

- $H = 60 + 18 + 57.5 = 135.5$ mm (18 = Sp spider - see page 31)
- Choose type of bell-housing (LMC - LMS):
For monobloc bell-housing LMC/LDC series see pages 75 ÷ 81
For Low noise bell-housing LMS/LDS series see pages 81 ÷ 89
For Multi-components 2-3 bell housing series see pages 91 ÷ 111

Note:

The length of bell-housing must be \geq than the length calculated (135.5 mm)

Case A

Solution with monobloc bell-housing series **LMC/LDC**

Pages 75 ÷ 81 for IEC Electric motor size 100-112 - LMC250

LMC 250 bell-housing with height ≥ 135.5 - LMC250AFSQ

The bell-housing code must be completed with pump drilling code (see pages 60-61).

For the specific case:

Spigot hole 82.55 - PCD 106.4 - Nr.2 holes M10 : Drilling code 060

Definitive bell-housing code **LMC250AFSQ060**

Case B

Solution with low noise bell-housing series **LMS/LDS**

Pages 83 ÷ 89 for IEC Electric motor size 100-112 - LMS250

LMS 250 bell-housing with height ≥ 135.5 - LMS250AFSA

The bell-housing code must be completed with pump drilling code (see pages 60-61).

For the specific case:

Spigot hole 82.55 - PCD 106.4 - Nr.2 holes M10 : Drilling code 060

Definitive bell-housing code **LMS250AFSA060**

Coupling selection

Motor half-coupling (see page 26)

For IEC Electric motor size 100/112, the half-coupling is **SGEA21M05060**

Spider (see page 31)

For SGEA21, EGE2 - EGE2RR

(choose spider material on the base of the application, oil, temperature and cycle machine, etc.)

Pump half-coupling

Choose the drilling code - see pages 18-19 for shaft 19.05 - key 4.76 - code: **G01**

Pump half-coupling length = BH length - THK Spider - THK Spigot

$$\text{LMC} = 138 \text{ mm} - 60 - 18 - 9.5 = 50.5 \text{ mm}$$

$$\text{LMS} = 148 \text{ mm} - 60 - 18 - 9.5 = 60.5 \text{ mm}$$

LMC - Choose the half-coupling's length at page 26 \leq 50.5 mm.

LMS - Choose the half-coupling's length at page 26 \leq 60.5 mm.

LMC - Available length for SGEA21 = 50 mm

LMS - Available length for SGEA21 = 60 mm

Half coupling for LMC: **SGEA21G01050**

Half coupling for LMS: **SGEA21G01050**

Note: for multi pumps we recommend to use a specific support on the base of the pump's dimensions and weight.

Noise is a particularly pervasive problem so much so that there have been statutory regulations in place now for some years, designed to limit harmful occupational exposure.

Many of the machines used in industry today are equipped with oil-hydraulic systems, which happen to be a major source of noise.

① THEORY AND DEFINITION OF NOISE

From a health and hygiene standpoint, noise can be defined as an unpleasant and undesirable sound, or an unpleasant and annoying or intolerable auditory sensation (noise being any sound phenomena that may be accompanied by sensations of disturbance and pain). By definition, acoustic phenomena are oscillatory in character, propagated in a flexible medium and causing pressure variations at the points, and the areas adjacent to those points, through which they pass.

② SOUND

Technically considered, certain elements must be present simultaneously for acoustic phenomena to occur:

- Sound source
- Transmission medium
- Receive

The electric motor and the pump, together with the drive coupling, are the SOURCE OF THE NOISE. The Bell-housing is the noise transmission MEDIUM. Depending on whether the monobloc bell-housing is a rigid or low noise type, there will be variations in the flexible properties of the transmission medium. The acoustic phenomena are dissimilar in the two cases, given the differences in pressure variation and particle displacement.

MOTOR AND PUMP UNIT

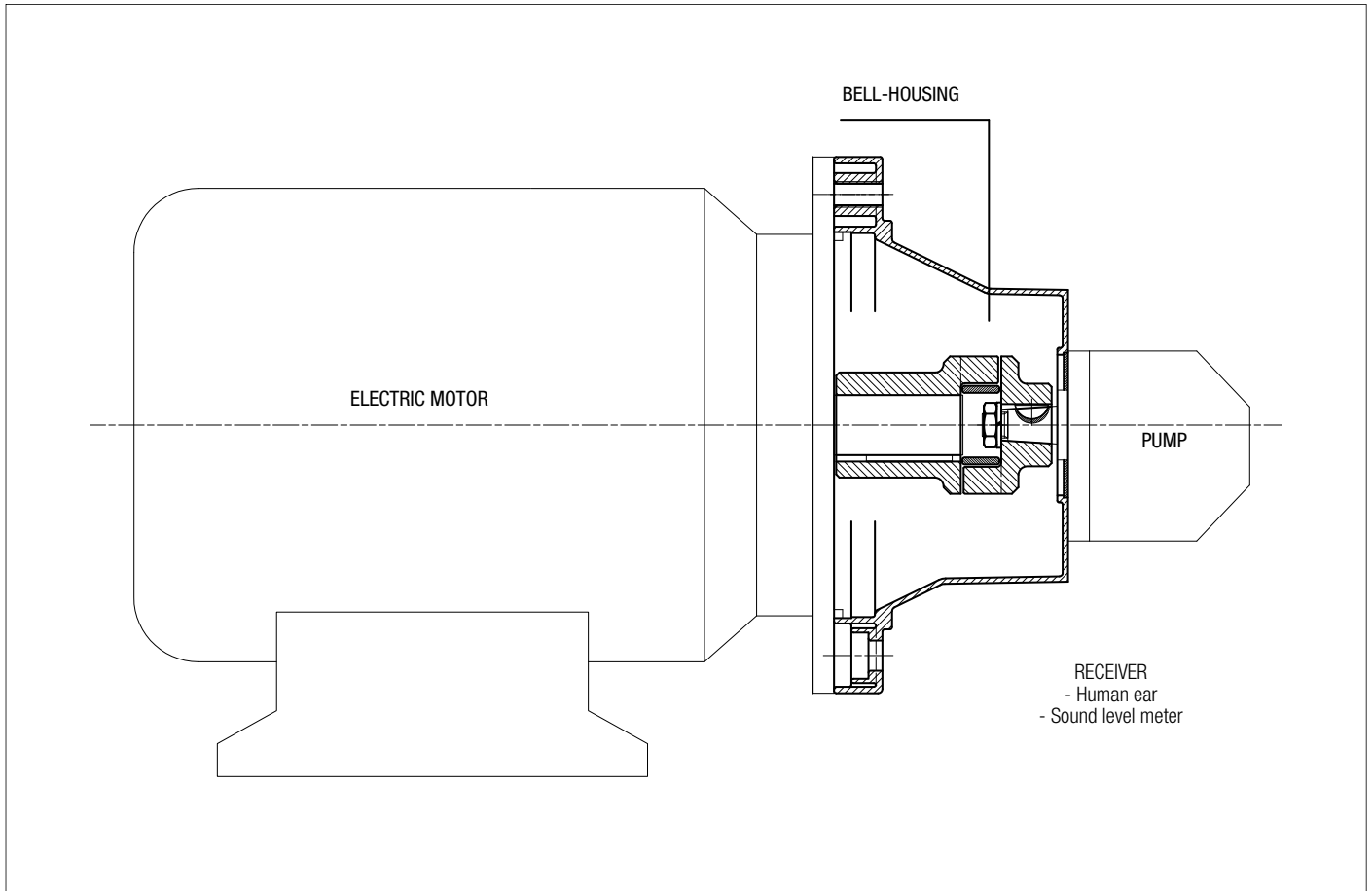

Low noise bell-housing will help to attenuate the transmission of vibrations and the emission of noise generated by the system.

Self-evidently, however, the mere adoption of a low noise bell-housing will achieve little unless the motor and pump are correctly installed on the machine or on the tank of the hydraulic power unit.

Should be followed in order to achieve best possible results and correct installation:

① MOTOR AND PUMP UNIT MOUNTED HORIZONTALLY ON OIL TANK LID

- The suction pipe attached to the pump must be rigid and fitted using a resilient bulkhead flange of the FTA series, which helps to cushion the vibrations propagated between the pipe and the tank lid.
If pipes need to be bent, the radius of curvature must be at least 3 times the pipe diameter.
Do not use elbow fittings, as these will significantly increase pressure losses.
- The pressure pipeline of the pump must be flexible and long enough to include bends with the minimum radius of curvature recommended by the manufacturer for the specified operating pressure.
- The return pipeline running from the service to the filter must be flexible.
Where oil is returned directly to the tank of the hydraulic power unit through a rigid pipe, it is advisable to use a resilient bulkhead flange of the FTR series, which helps to cushion the vibrations propagated between the pipe and the tank lid.
- Anti-vibration devices (resilient mounts or damping rods) must be located under the feet of the electric motor or the PDM foot brackets, depending on the mounting position of the motor.
- The lids of hydraulic oil tanks must be sturdy enough to support the load they carry.

② MOTOR AND PUMP UNIT MOUNTED HORIZONTALLY ON MACHINE

- As a matter of good practice, the oil tank and motor-pump unit should be mounted on a single supporting frame of strength sufficient to support the load.
- If the hydraulic system is fitted with a side-mounted filter, the suction pipeline to the pump must be flexible and long enough to include bends with the minimum radius of curvature recommended by the manufacturer.
- If the suction filter is not side mounted, the pipeline should be rigid and installed in conjunction with a compensating coupling.
- The pressure pipeline of the pump must be flexible, and long enough to include bends with the minimum radius of curvature recommended by the manufacturer for the specified operating pressure.
- The return pipeline running from the service to the filter must be flexible.
Where oil is returned directly to the tank of the hydraulic power unit through a rigid pipe, it is advisable to use a resilient bulkhead flange of the FTR series, which helps to cushion the vibrations propagated between the pipe and the tank lid.
- Anti-vibration devices (resilient mounts or damping rods) must be located under the feet of the electric motor or the PDM foot brackets, depending on the mounting position of the motor.

FINAL CONSIDERATION

For best results, in any event, the motor-and-pump unit should be incorporated into the hydraulic system in such a way that no one component is rigidly associated with another, resulting in the propagation of vibration, and consequently noise.

RECOMMENDED TIGHTENING TORQUES FOR MOTOR/PUMP FIXING ON THE BELL-HOUSING

M6	10 N·m	M16	205 N·m
M8	15 N·m	M18	280 N·m
M10	50 N·m	M20	400 N·m
M12	84 N·m	M22	530 N·m
M14	135 N·m	M24	690 N·m

Note: The above guidelines are indicative only and subordinate to the solutions adopted ultimately by design engineers.

Valid configuration for bell-housing up to Ø400

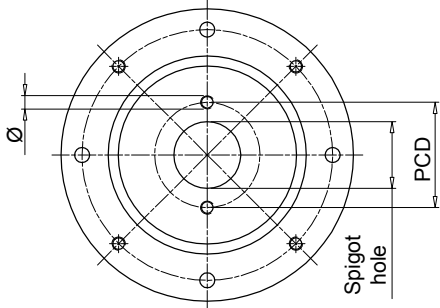

Bell-housing with nr. 2 holes at pump interface, aligned with through holes at motor interface.

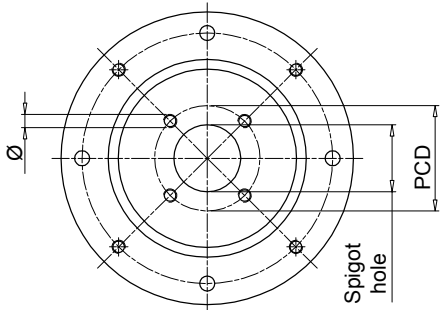

Bell-housing with nr. 4 holes at pump interface, aligned with thread holes at motor interface.

Valid configuration for bell-housing from Ø450 to Ø660

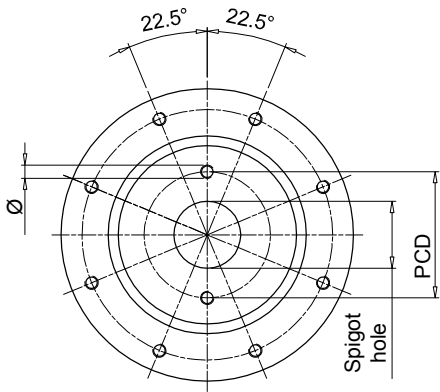

Bell-housing with nr. 2 holes at pump interface + 22.5° compared to through holes at motor interface.

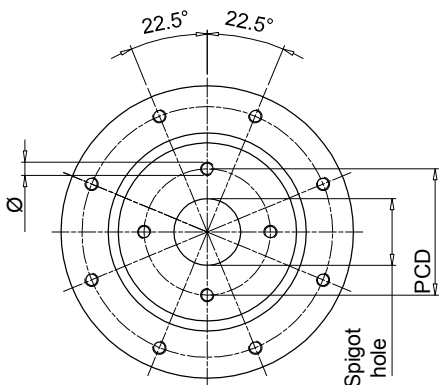

Bell-housing with nr. 4 holes at pump interface + 22.5° compared to thread holes at motor interface.

Spigot hole [mm]	PCD	Ø	Nr. holes	Code	Type
40	72.00	M8	2	191	-
45.2	88.90	M8	4	096	-
	71.80	M8	4	120	-
50	80.00	M8	2	052	ISO3019-2-50-B2
	93.00	M10	2	053	-
	60.00	M5	4	280	-
	63.00	Ø7	4	057	-
50.8	93.00	M8	2	287	-
	82.50	M8	2	050	SAE A-A 50-2
56	76.00	M6	4	234	-
57.15	106.40	Ø11	2	212	-
60	74.00	M10	4	098	-
	98.50	M6	4	147	-
62.7	75.00	M6	4	227	-
	157.20	M12	4	231	-
63	100.00	M8	2	042	ISO3019-2-63-B2
	125.00	M6	4	043	-
	85.00	M8	4	044	-
	80.00	M8	2	051	-
	80.00	Ø8.5	4	058	-
	100.00	M10	2	062	-
	82.00	M8	4	168	ISO3019-2-63-B4
	90.00	M8	4	271	-
65	90.00	M8	4	073	-
70	84.00	Ø7	4	289	-
71.8	88.90	M10	4	047	-
75	102.00	M10	4	139	-
80	100.00	M8	4	024	ISO3019-2-80-B4
	103.20	M8	2	045	ISO3019-2-80-B2
	100.00	Ø11	4	059	-
	100.00	M10	2	061	-
	110.00	M10	2	063	-
	140.00	M10	2	064	-
	115.00	M10	2	065	-
	100.00	M10	4	067	-
	106.40	M10	2	083	-
	130.00	M8	4	087	-
	100.00	Ø8.5	4	093	-
	113.00	M12	4	104	-
82.55	95.00	M8	4	169	-
	103.00	M8	4	242	-
	110.00	M10	4	272	-
	106.40	M10	2	060	SAE A 82-2
	105.00	M10	4	097	-
	106.40	M8	2	254	-
	146.00	M12	2	260	-
	110.00	M10	2	284	-
85	106.40	M10	2	066	-
90	112.00	M8	2	134	-
	105.00	M8	4	156	-
	118.00	Ø9	2	163	-
92	112.00	Ø9	2	164	-
	140.00	M8	4	088	-
	145.00	M10	4	089	-

"-": configuration out of ISO & SAE Standard

Spigot hole [mm]	PCD	Ø	Nr. holes	Code	Type
95	115.00	M8	4	137	-
	127.00	M10	4	131	-
98.4	125.00	Ø11	4	128	-
100	125.00	M10	2	023	ISO3019-2-100-B4
	125.00	M10	4	025	ISO3019-2-100-B2
	125.00	Ø11	4	031	-
	125.00	M5	4	032	-
	190.00	Ø15	4	038	-
	125.00	Ø13	4	041	-
	125.00	M12	2	071	-
	140.00	M12	2	072	-
	146.00	M12	2	075	-
	126.00	M10	2	106	-
	120.00	M8	4	122	-
	160.00	M10	4	141	-
150.00	M10	4	150	-	
101.6	161.50	M12	4	029	-
	146.00	M12	2	070	SAE B 101-2
	127.00	M12	4	125	-
	146.00	M10	2	159	-
105	127.00	M10	4	224	-
	146.00	M12	2	076	-
110	175.00	M10	4	110	-
	130.00	M8	4	154	-
	200.00	M10	4	202	-
	135.00	M10	4	219	-
112	145.00	M12	4	273	-
	140.00	M12	2	074	-
115	140.00	M10	2	138	-
	130.00	M10	4	264	-
116	180.00	M12	4	198	-
120	160.00	M14	2	084	-
	210.00	M16	2	094	-
	145.00	M10	4	155	-
125	150.00	Ø13	4	267	-
	160.00	M12	4	026	ISO3019-2-125-B4
	160.00	Ø13	4	033	-
	160.00	M12	2	079	-
	180.00	M16	2	082	ISO3019-2-125-B2
	155.00	M10	4	102	-
	160.00	Ø17	4	113	-
	200.00	M12	4	114	-
	181.20	M16	2	136	-
	200.00	M16	4	200	-
127	180.00	Ø20	4	215	-
	170.00	Ø18	4	237	-
	161.50	M12	4	021	-
130	181.20	M16	2	080	SAE C 127-2
	161.50	M14	4	140	-
130	165.00	Ø11	4	054	-
	150.00	M12	4	068	-
	181.20	M16	2	085	-
	165.00	M12	4	124	-
	165.00	M14	4	135	-

"-": configuration out of ISO & SAE Standard

Spigot hole [mm]	PCD	Ø	Nr. holes	Code	Type
130	165.00	M10	4	253	-
135	160.00	M10	4	151	-
	175.40	M12	4	220	-
140	180.00	M14	4	077	ISO3019-2-140-B4
	180.00	M12	2	081	-
	165.00	M10	4	157	-
	200.00	M16	4	176	ISO3019-2-140-B2
	165.00	Ø11	4	223	-
150	180.00	M16	2	232	-
	185.00	M16	4	069	-
152.4	228.60	M16	4	022	-
	228.60	M18	2	090	-
	228.60	M18	4	108	-
	217.50	Ø17	4	118	-
	228.60	M20	2	166	SAE D 152-2
	228.60	M20	4	192	SAE D 152 -4
160	190.50	M8	4	207	-
	200.00	M16	4	027	ISO3019 - 2 -160 B4
	200.00	Ø17	4	035	-
	200.00	M16	2	091	-
	224.00	M20	2	092	ISO3019 - 2 -160 B2
	200.00	M12	2	107	-
	230.00	M22	4	111	-
	185.00	M12	4	152	-
162	224.00	M16	4	184	-
	230.00	Ø22	4	228	-
165.1	188.00	M12	4	263	-
	317.35	M20	4	143	SAE E 165 - 4
	317.35	M24	2	145	SAE E 165 - 2
175	229.00	M20	4	201	-
	317.35	M18	4	204	-
177.8	200.00	M12	4	153	-
	230.00	M18	2	185	-
180	350.00	M24	4	146	SAE F 177 - 4
	216.00	M12	4	222	-
	350.00	M24	2	203	SAE F 177 - 2
	216.00	Ø13	4	055	-
200	216.00	M16	4	078	-
	224.00	M16	4	112	ISO3019 - 2 -180 B4
	216.00	M12	4	132	-
	215.00	M22	4	148	-
	230.00	M22	4	226	-
	250.00	M20	4	028	ISO3019 - 2 -200 B4
203.2	250.00	Ø22	4	095	-
	280.00	M24	2	117	-
205	230.50	M12	4	214	-
	254.00	M14	4	210	-
224	240.00	M16	4	133	-
	280.00	M20	4	144	ISO3019 - 2 -224 B4
250	280.00	Ø22	4	205	-
	310.00	M24	4	238	-
275	315.00	M20	4	282	ISO3019 - 2 -250 B4
	355.00	M16	4	233	-
	355.00	Ø18	4	281	-

"-": configuration out of ISO & SAE Standard

Technical data

Modular Bell-Housing Components - IEC electric motor range from size 132 up to size 355

Materials

- Base module: Pressure die-cast aluminium alloy
- Pump flange: Aluminium alloy
- Intermediate adapter: Aluminium alloy.
- Screw kit: Steel
- Gaskets: Special paper (Guarnital)

Compatibility with fluids

Modular bell-housing components compatible for use with:

- Mineral oils types HH-HL-HM-HR-HV, to ISO 6743/4 standard
- Water based emulsions types HFAE-HFAS, to ISO 6743/4 standard
- Water glycol type HFC, to ISO 6743/4 standard: ask for anodized version

Special Applications

Any applications not covered by the normal indications contained in this catalogue must be evaluated and approved by MP Filtri Technical and Sales Department

Temperature

From -30 °C to +80 °C

Note

For temperatures outside this range, contact MP Filtri Technical and Sales Department



GENERAL INFORMATION MULTI-COMPONENTS

BMC

Bell-Housing size	Flange ISO 3019-2							IEC Motors size	
	50 B2-B4	63 B2-B4	80 B2-B4	100 B2-B4	125 B2-B4	160 B2-B4	200 B2-B4		
BMC200	●	●	●	●				IEC 80 Ø200 - Ø19x40	
BMC200	●	●	●	●				IEC 90 Ø200 - Ø24x50	
BMC250	●	●	●	●	●			IEC 100 Ø250 - Ø28x60	
BMC250	●	●	●	●	●			IEC 112 Ø250 - Ø28x60	
BMC300			●	●	●	●		IEC 132 Ø300 - Ø38x80	
BMC350			●	●	●	●		IEC 160 Ø350 - Ø42x110	
BMC350			●	●	●	●	●	IEC 180 Ø350 - Ø48x110	
BMC400			●	●	●	●	●	IEC 200 Ø400 - Ø55x110	
BMC450			●	●	●	●	●	IEC 225 Ø450 - Ø60x140	

Bell-Housing size	Flange SAE J 744										IEC Motors size	
	50-2 (A-A)	82-2 (A)	101-2 (B)	127-2 (C)	152-2 (D)	165-2 (E)	101-4 (B)	127-4 (D)	152-4 (D)	165-4 (E)		
BMC200	●	●									IEC 80 Ø200 - Ø19x40	
BMC200	●	●									IEC 90 Ø200 - Ø24x50	
BMC250	●	●	●				●				IEC 100 Ø250 - Ø28x60	
BMC250	●	●	●	●			●				IEC 112 Ø250 - Ø28x60	
BMC300		●	●	●			●	●			IEC 132 Ø300 - Ø38x80	
BMC350		●	●	●			●	●			IEC 160 Ø350 - Ø42x110	
BMC350		●	●	●	●		●	●	●		IEC 180 Ø350 - Ø48x110	
BMC400		●	●	●	●	●	●	●	●	●	IEC 200 Ø400 - Ø55x110	
BMC450			●	●	●	●	●	●	●	●	IEC 225 Ø450 - Ø60x140	

BMT

Bell-Housing size	Flange ISO 3019-2							IEC Motors size	
	50 B2-B4	63 B2-B4	80 B2-B4	100 B2-B4	125 B2-B4	160 B2-B4	200 B2-B4		
BMT300			●	●	●	●		IEC 132 Ø300 - Ø38x80	
BMT350			●	●	●	●		IEC 160 Ø350 - Ø42x110	
BMT350			●	●	●	●	●	IEC 180 Ø350 - Ø48x110	
BMT400			●	●	●	●	●	IEC 200 Ø400 - Ø55x110	
BMT450			●	●	●	●	●	IEC 225 Ø450 - Ø60x140	
BMT550					●	●	●	IEC 250 Ø550 - Ø65x140	
BMT550					●	●	●	IEC 280 Ø550 - Ø75x140	
BMT660					●	●	●	IEC 315 Ø660 - Ø80x170	
BAD800					●	●	●	IEC 355 Ø800 - Ø95x210	

Bell-Housing size	Flange SAE J 744										IEC Motors size	
	50-2 (A-A)	82-2 (A)	101-2 (B)	127-2 (C)	152-2 (D)	165-2 (E)	101-4 (B)	127-4 (D)	152-4 (D)	165-4 (E)		
BMT300		●	●	●			●	●			IEC 132 Ø300 - Ø38x80	
BMT350		●	●	●			●	●			IEC 160 Ø350 - Ø42x110	
BMT350		●	●	●	●		●	●	●		IEC 180 Ø350 - Ø48x110	
BMT400		●	●	●	●	●	●	●	●	●	IEC 200 Ø400 - Ø55x110	
BMT450			●	●	●	●	●	●	●	●	IEC 225 Ø450 - Ø60x140	
BMT550				●	●	●	●	●	●	●	IEC 250 Ø550 - Ø65x140	
BMT550				●	●	●	●	●	●	●	IEC 280 Ø550 - Ø75x140	
BMT660				●	●	●	●	●	●	●	IEC 315 Ø660 - Ø80x170	
BAD800				●	●	●	●	●	●	●	IEC 355 Ø800 - Ø95x210	

MULTI-COMPONENTS

Designation & Ordering code

BMC

1 Motor base series and size			Configuration example: BMC200A1001	DI
BMC200A1001	BMC300A1551	BMC400A2016		
BMC200A1251	BMC300A1555	BMC450A2507		
BMC250A1141	BMC300A1705			
BMC250A1361	BMC350A1945			
	BMC350A1946			
BMT300A0805	BMT550A21567			
BMT350A1105	BMT660A25067			
BMT400A1106	BAD800A2707			
BMT450A1406				

Options	
DI	Drain hole + inspection hole
AN	Black anodized finish
SA	Clearance holes at motor interface
Pxx	Customer specification

2 Intermediate adapter series and size			Configuration example: AD60465	AN
AD60465				
AD50385				
AD60466				
AD50386				
AD50467				
AD60467				

Options	
AN	Black anodized finish
Pxx	Customer specification

3 Pump flange series and size				Configuration example: FP5026	070	AN
FR1023	FP5026	FP6032	FP7052			
FR1025	FP5032	FP6045	FP7066			
FR1033	FP5035	FP6058	FP7069			
FR1035	FP5045	FP6070	FP7086			
FR1040	FP5056	FP6082	FP70111			
FR1079	FP5063	FP6086				
	FP5091	FP60101				
		FP60110				

Pump interface codes	
070	See page 60

Options	
FR	Holes rotated through 45° in relation to standard position
DP	Double set of hole
AN	Black anodized finish
Pxx	Customer specification

Options	
Mounting kit code series and size	
KVG1	
KVG5	
KVG6	See page 111
KVG7	

1

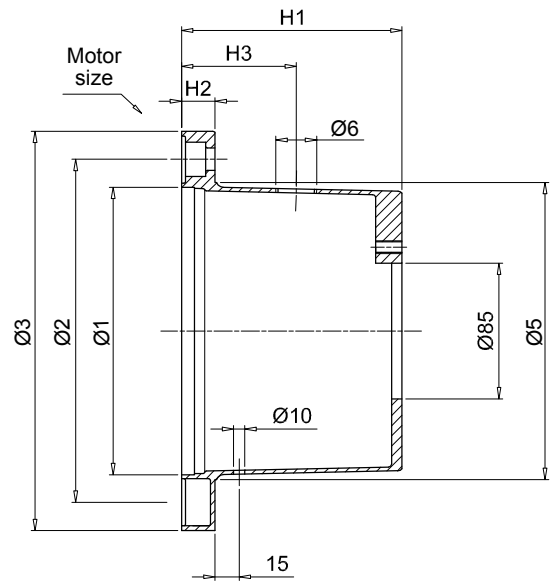
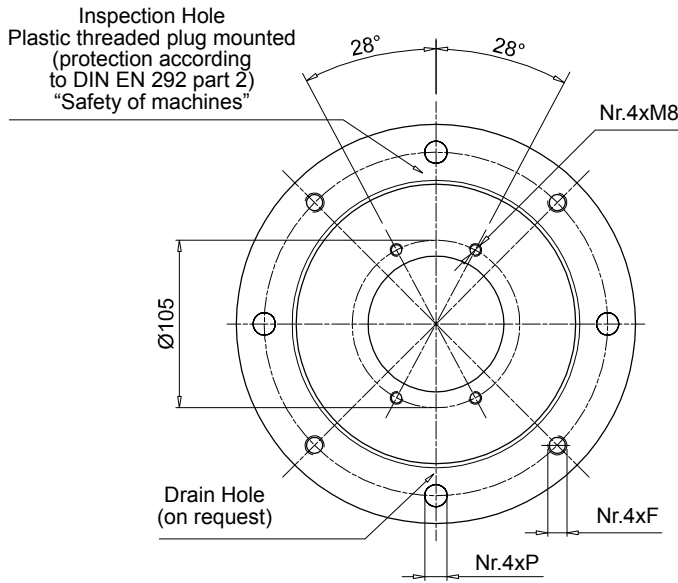

IEC - Electric motors		Motor base code	Dimensions [mm]								On request		Weight [kg]
Motor size	Shaft end [Ø x L]		Ø1	Ø2	Ø3	Ø5	H1	H2	F	P	H3	Ø6	
80	19x40	BMC200A1001	130	165	200	135	100	18	M10	11	60	3/4"	0.75
90	24x50	BMC200A1251	130	165	200	135	125	18	M10	11	75	3/4"	0.95
100-112	28x60	BMC250A1141	180	215	250	186	114	19	M12	14	80	3/4"	1.60
		BMC250A1361	180	215	250	186	138	19	M12	14	100	3/4"	1.60
132	38x80	BMC300A1551	230	265	300	235	155	23	M12	14	95	3/4"	3.30

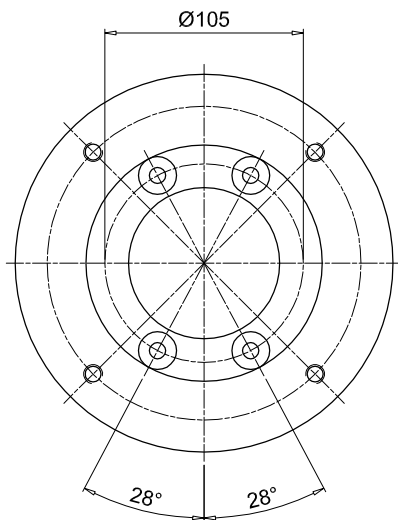

4 Bolt Version

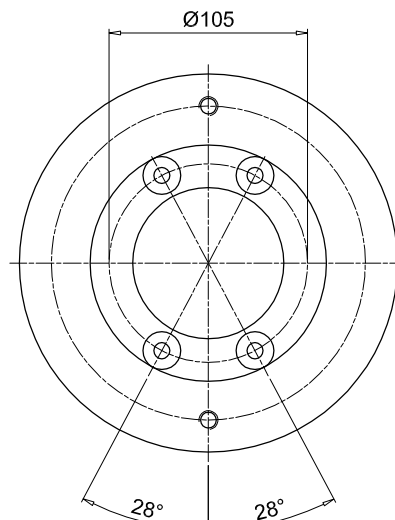

2 Bolt Version

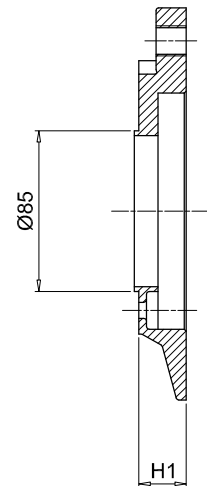

The codes on the chart must be used for dimensional checking only; the ordering codes for all components are available on the on-line software "Power Transmission Software" on the web site www.mpfiltri.com

3

Pump flange code	H1	Mounting kit	Available pump interface		Weight [kg]
			2 Bolt	4 Bolt	
FR1023***	23	KVG1 See page 111	D042 - S061 - S063 - S083 - S023 - S070 - S071 - S082 - S075	S024 - S025 - S125 - S154	0.25
FR1025***	25		S080 - S082	S021 - S026 - S068 - S069	0.30
FR1033***	33		S023 - S070 - S071 - S072 - S074 S080 - S082	S021 - S026 - S027	0.80
FR1035***	35		S060 - S063 - S065	-	0.90
FR1040***	40		-	S098 - S227	1.10
FR1079***	79		-	S031	1.30

Pump flange code to be complete with available pump interface

Example: **FR1023S024**

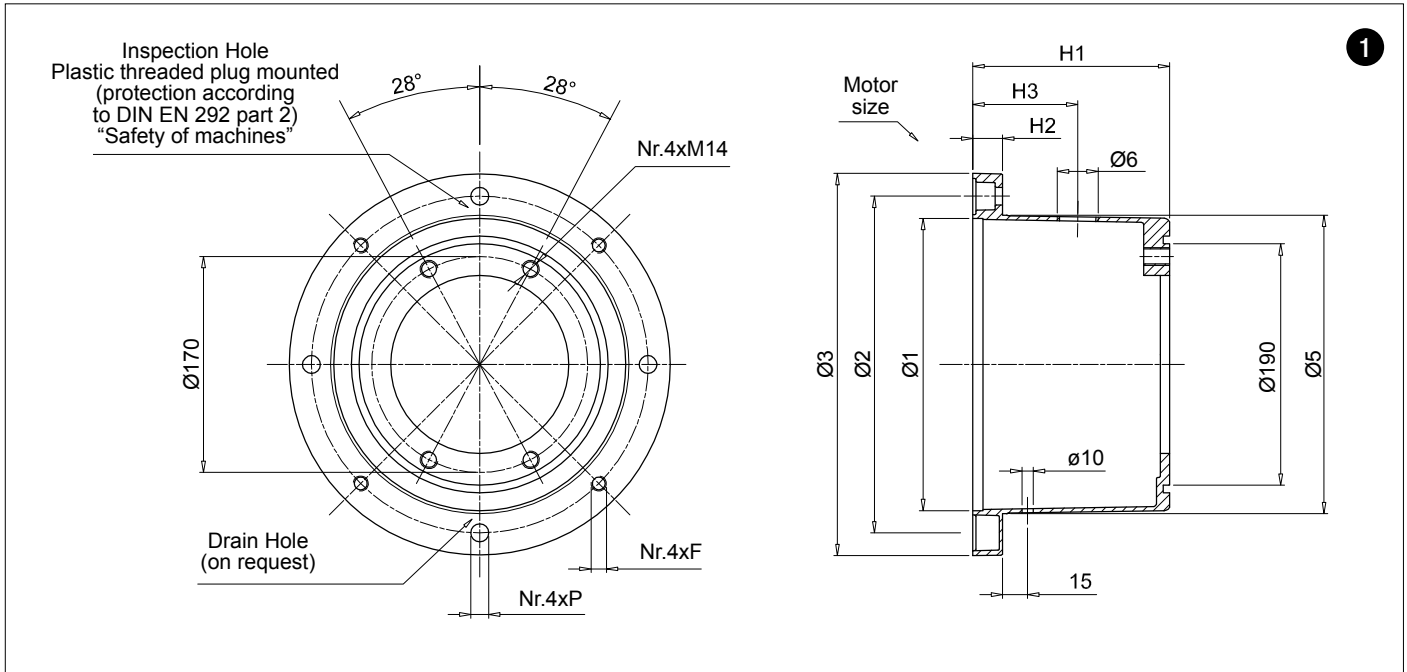

IEC - Electric motors		Motor base code	Dimensions [mm]								On request		Weight [kg]
Motor size	Shaft end [Ø x L]		Ø1	Ø2	Ø3	Ø5	H1	H2	F	P	H3	Ø6	
132	38x80	BMC300A1555	230	265	300	235	155	23	M12	14	95	3/4"	3.3
		BMC300A1705	230	265	300	235	170	23	M12	14	110	3/4"	3.6
160	42x110	BMC350A1785	250	300	350	254	178	31	M16	18	100	1"	4.4
180	48x110	BMC350A1945	250	300	350	254	194	31	M16	18	115	1"	4.9

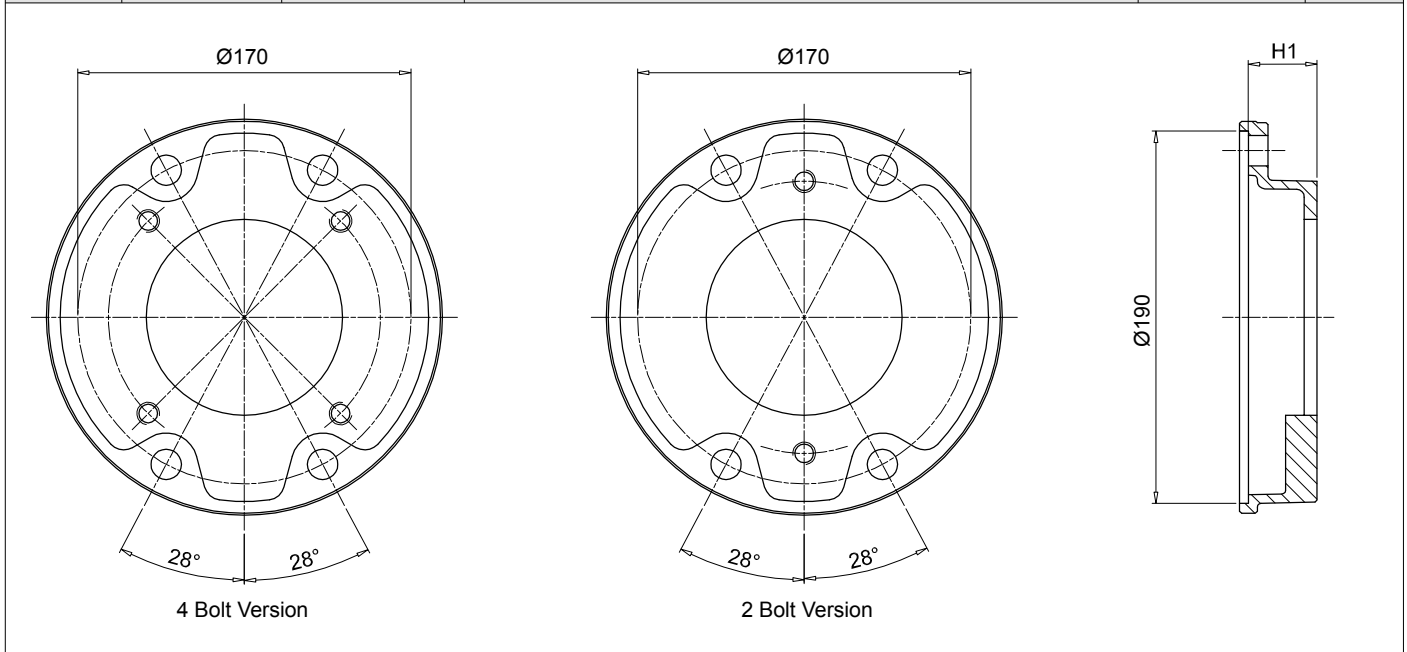

The codes on the chart must be used for dimensional checking only; the ordering codes for all components are available on the on-line software "Power Transmission Software" on the web site www.mpfiltri.com

Pump flange code	H1	Mounting kit	Available pump interface		Weight [kg]
			2 Bolt	4 Bolt	
FP5026***	26	KVG5 See page 111	S023 - D042 - S063 - S070 - S072 S075	S024 - S024 - S033 - S125 - S154	1.0
FP5032***	32		-	S024 - S031 - S096 - S125	1.1
FP5035***	35		S023 - D042 - S063 - S070 - S072 - S075 - S060 - S072 - S074 - S075 - S106	S021 - S024 - S025 - S026 - S031 - S059 - S068 - S083 - S097 - S125 - S141	0.9
FP5045***	45		S060 - S070 - S071 - S072 - S074 - S075 - S106	S021 - S024 - S025 - S026 - S068 - S125 - S141	0.9
FP5056***	56		S072	S021 - S026	1.6
FP5063***	63		S070 - S079 - S138	S021 - S025 - S068 - S141	1.7
FP5091***	91		-	S025 - S031 - S033 - S113 - S267	2.2

Pump flange code to be complete with available pump interface

Example: **FP5026S023**

1

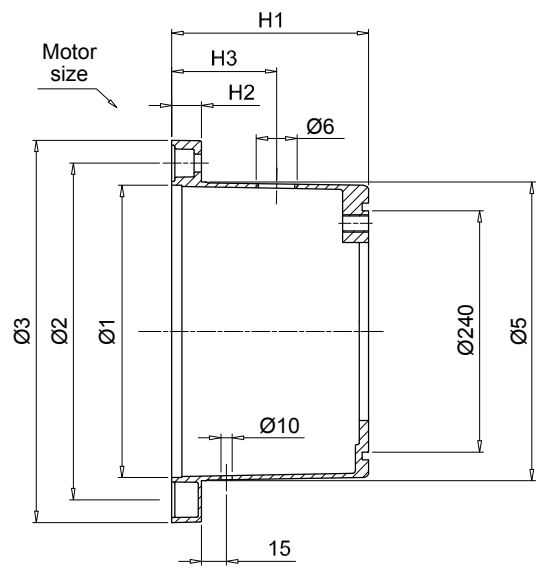
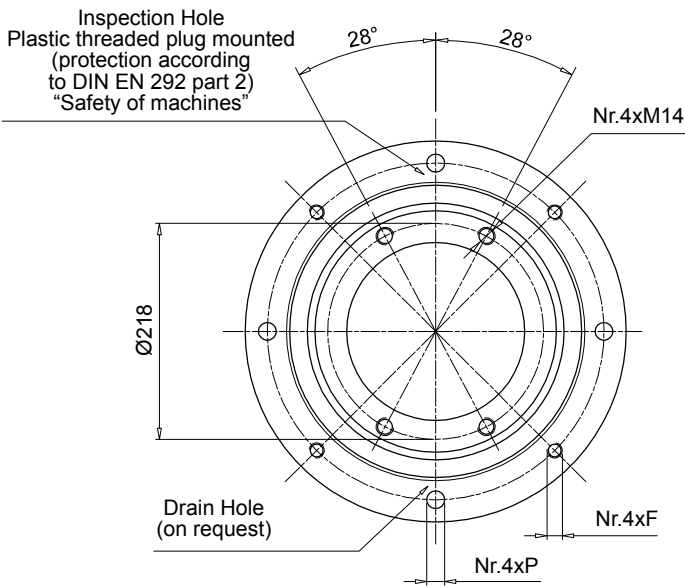

IEC - Electric motors		Motor base code	Dimensions [mm]							On request		Weight [kg]	
Motor size	Shaft end [Ø x L]		Ø1	Ø2	Ø3	Ø5	H1	H2	F	P	H3		Ø6
160	42x110	BMC350A1786	250	300	350	254	178	31	M16	18	100	1"	4.4
180	48x110	BMC350A1946	250	300	350	254	194	31	M16	18	115	1"	1.9
200	55x110	BMC400A2016	300	350	400	305	201	31	M16	18	125	1 1/2"	6.9

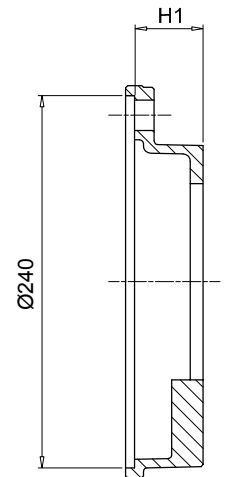
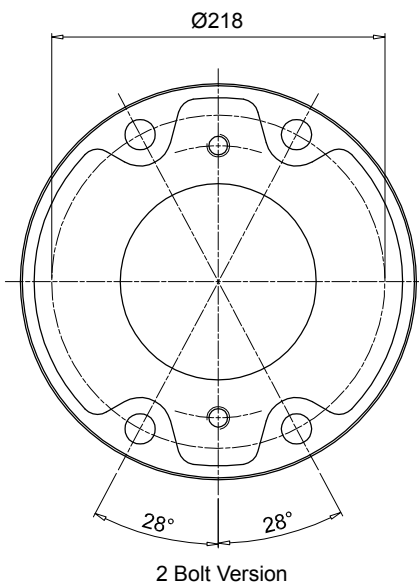
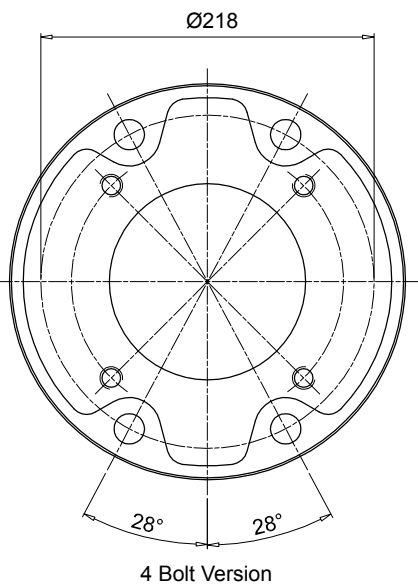

The codes on the chart must be used for dimensional checking only; the ordering codes for all components are available on the on-line software "Power Transmission Software" on the web site www.mpfiltri.com

3

Pump flange code	H1	Mounting kit	Available pump interface		Weight [kg]
			2 Bolt	4 Bolt	
FP6032***	32	KVG6 See page 111	S081 - S082	S021 - S035	1.8
FP6045***	45		S070 - S075 - S080 - S081 - S082	S021 - S025 - S026 - S027 - S069 - S077 - S125 - S198 - S207 - S215 - S253	2.1
FP6058***	58		S079 - S080 - S081 - S082	S025 - S026 - S027 - S038 - S077 - S078 - S207 - S215 - S237	2.4
FP6070***	70		S080	-	3.0
FP6082***	82		S080 - S081	S038 - S141 - 198 - 215	3.3
FP6086***	86		S090 - S092 - S166 - S091	S021 - S026 - S027 - S077 - S078 - S114 - S132 - 198 - S200	3.4
FP6101***	101		-	S027 - S035 - S113 - S132 - S148 - S176 - S228	4.2
FP6110***	110		S080	S111	5.5

Pump flange code to be complete with available pump interface
Example: **FP6032S021**

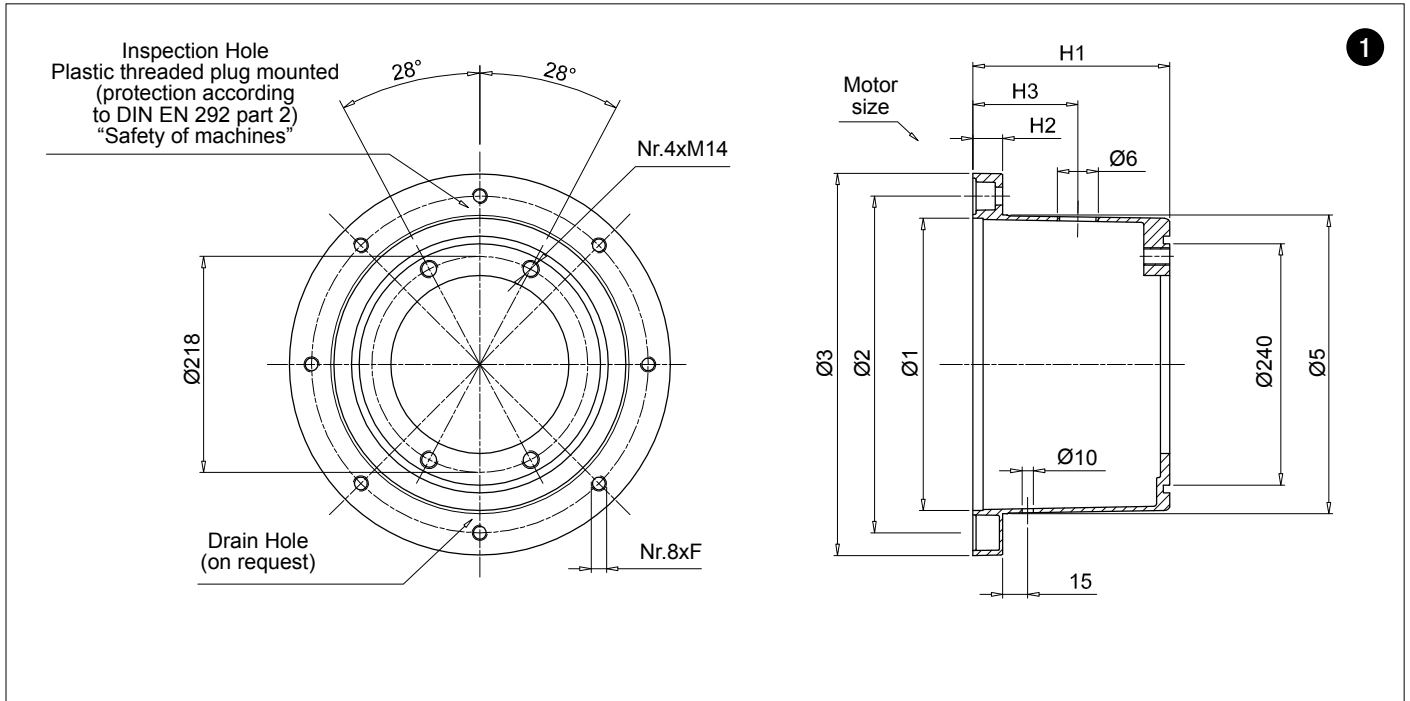

IEC - Electric motors		Motor base code	Dimensions [mm]								On request		Weight [kg]
Motor size	Shaft end [Ø x L]		Ø1	Ø2	Ø3	Ø5	H1	H2	F	P	H3	Ø6	
225	60x140	BMC450A2506	350	400	450	350	250	31	M16	-	175	1 1/2"	6.9

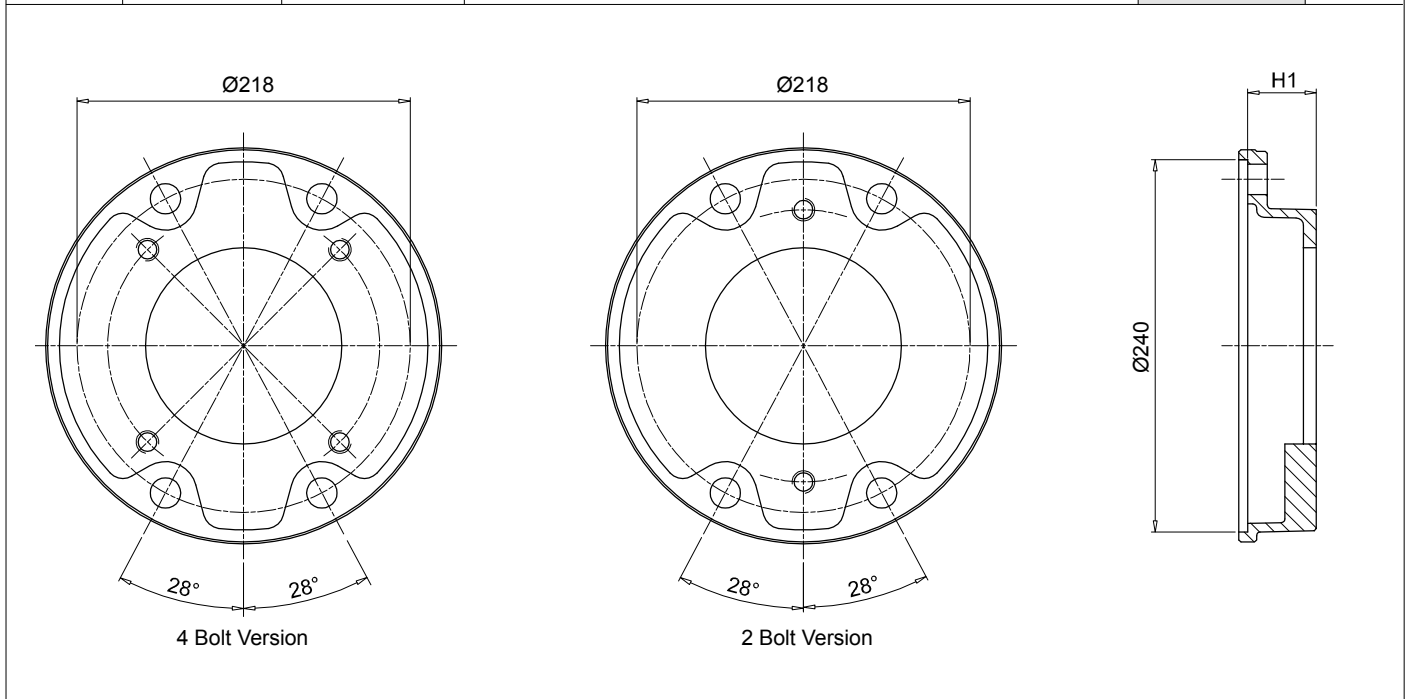

The codes on the chart must be used for dimensional checking only; the ordering codes for all components are available on the on-line software "Power Transmission Software" on the web site www.mpfiltri.com

Pump flange code	H1	Mounting kit	Available pump interface		Weight [kg]
			2 Bolt	4 Bolt	
FP6032***	32	KVG6 See page 111	S081 - S082	S021 - S035	1.8
FP6045***	45		S070 - S075 - S080 - S081 - S082	S021 - S025 - S026 - S027 - S069 - S077 - S125 - S198 - S207 - S215 - S253	2.1
FP6058***	58		S079 - S080 - S081 - S082	S025 - S026 - S027 - S038 - S077 - S078 - S207 - S215 - S237	2.4
FP6070***	70		S080	-	3.0
FP6082***	82		S080 - S081	S038 - S141 - 198 - 215	3.3
FP6086***	86		S090 - S092 - S166 - S091	S021 - S026 - S027 - S077 - S078 - S114 - S132 - 198 - S200	3.4
FP6101***	101		-	S027 - S035 - S113 - S132 - S148 - S176 - S228	4.2
FP6110***	110		S080	S111	5.5

Pump flange code to be complete with available pump interface

Example: **FP6032S021**

1

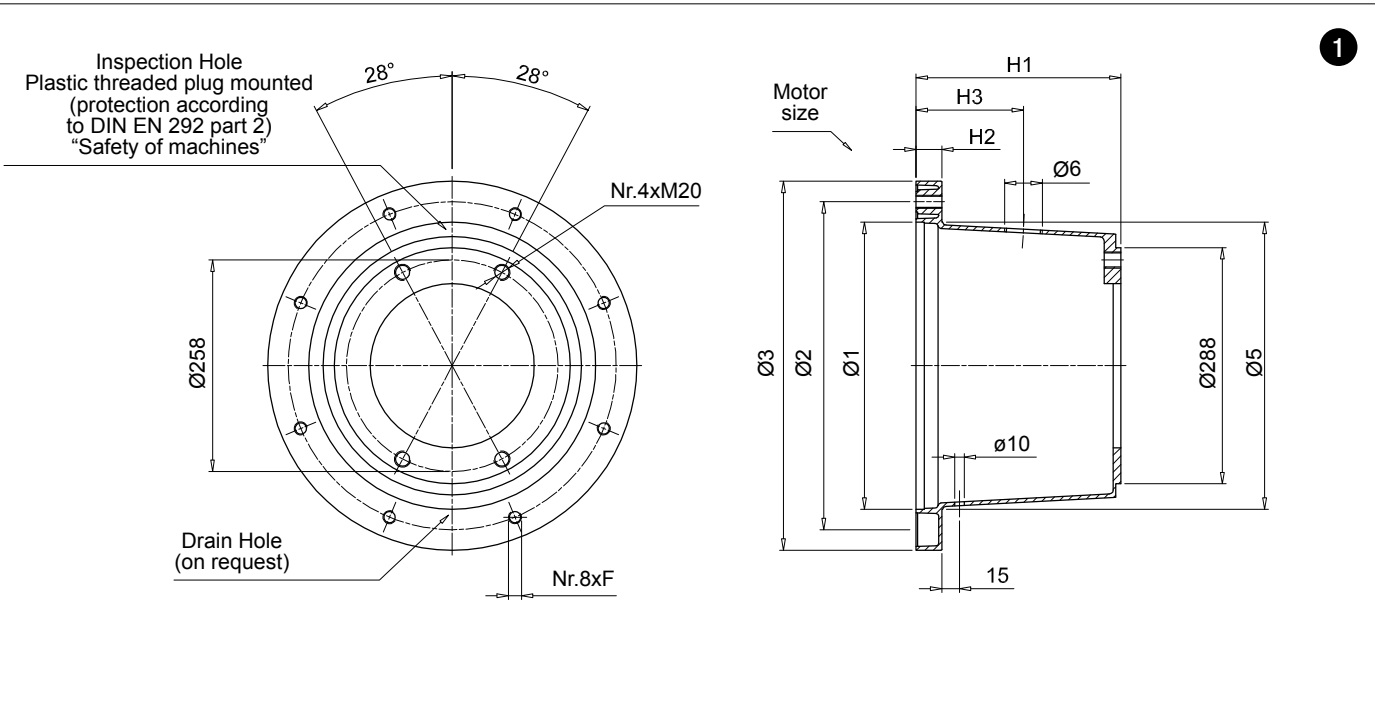

IEC - Electric motors		Motor base code	Dimensions [mm]								On request		Weight [kg]
Motor size	Shaft end [Ø x L]		Ø1	Ø2	Ø3	Ø5	H1	H2	F	P	H3	Ø6	
225	60x140	BMC450A2507	350	400	450	350	250	31	M16	-	175	1 1/2"	6.9

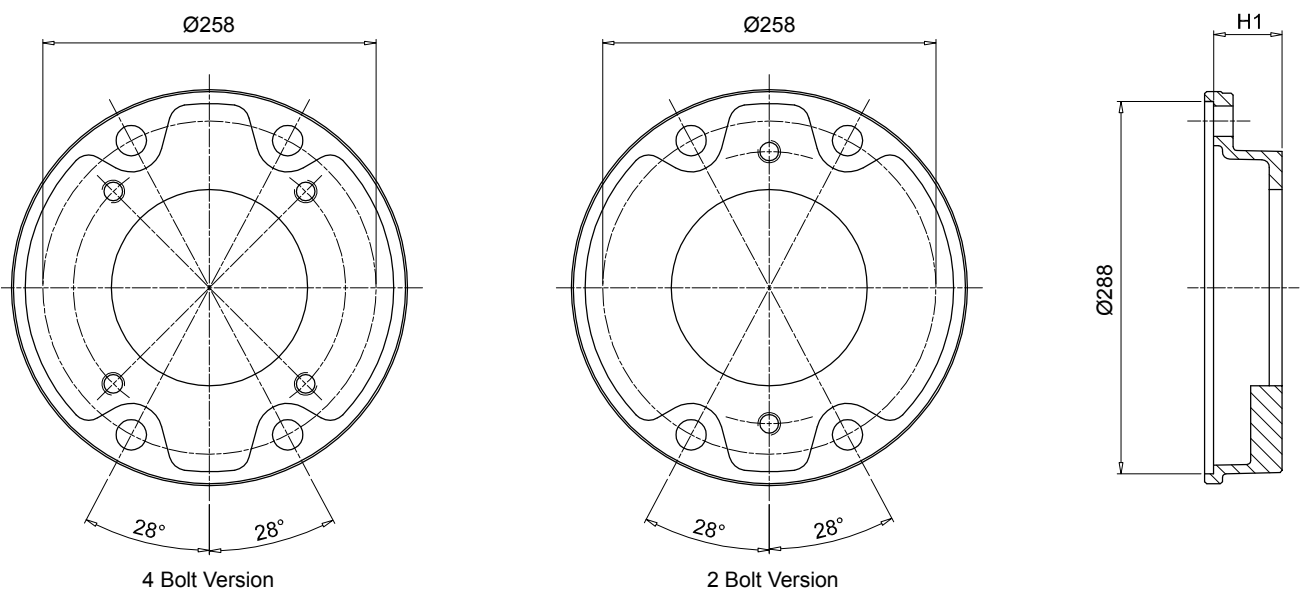

The codes on the chart must be used for dimensional checking only; the ordering codes for all components are available on the on-line software "Power Transmission Software" on the web site www.mpfiltri.com

3

Pump flange code	H1	Mounting kit	Available pump interface		Weight [kg]
			2 Bolt	4 Bolt	
FP7052***	52	KVG7 See page 111	-	S028 - S108 - S112 - S133 - S192	4.4
FP7066***	66		S090 - S092 - S166	-	4.8
FP7069***	69		-	S108 - S143 - S148 - S192 - S201 - S204 - S281 - S282	4.9
FP7086***	86		S091 - S092 - S117 - S166	S022 - S027 - S028 - S108 - S112 - S184 - S192 - S201 - S228 - S300	5.2
FP7111***	111		S091 - S092 - S117 - S145	S028 - S108 - S112 - S133 - S184	6.3

Pump flange code to be complete with available pump interface
 Example: **FP7052S028**

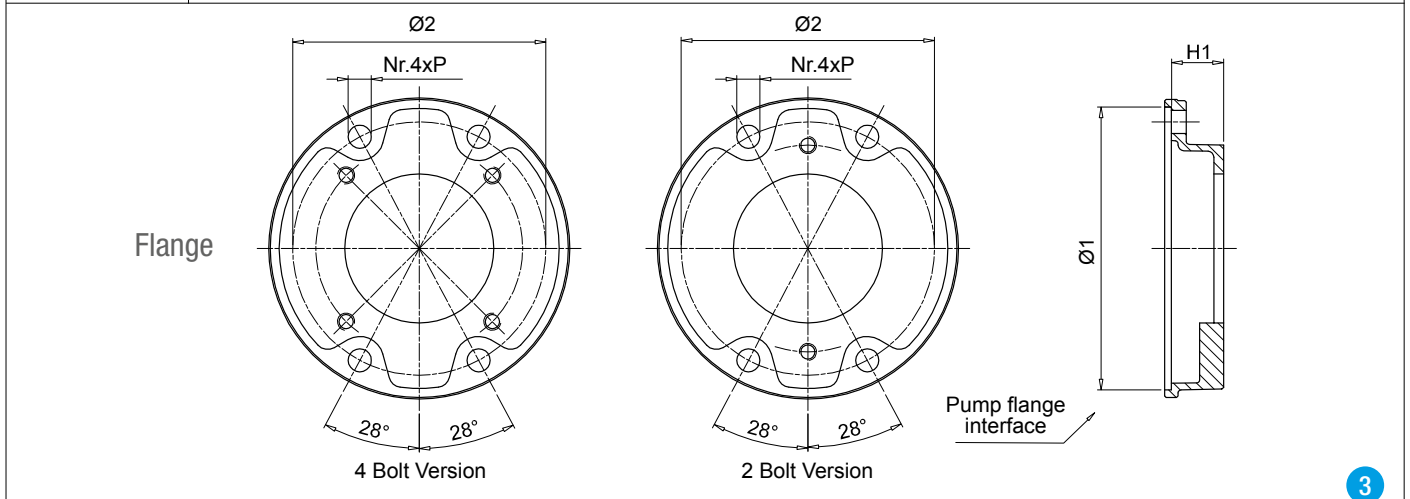
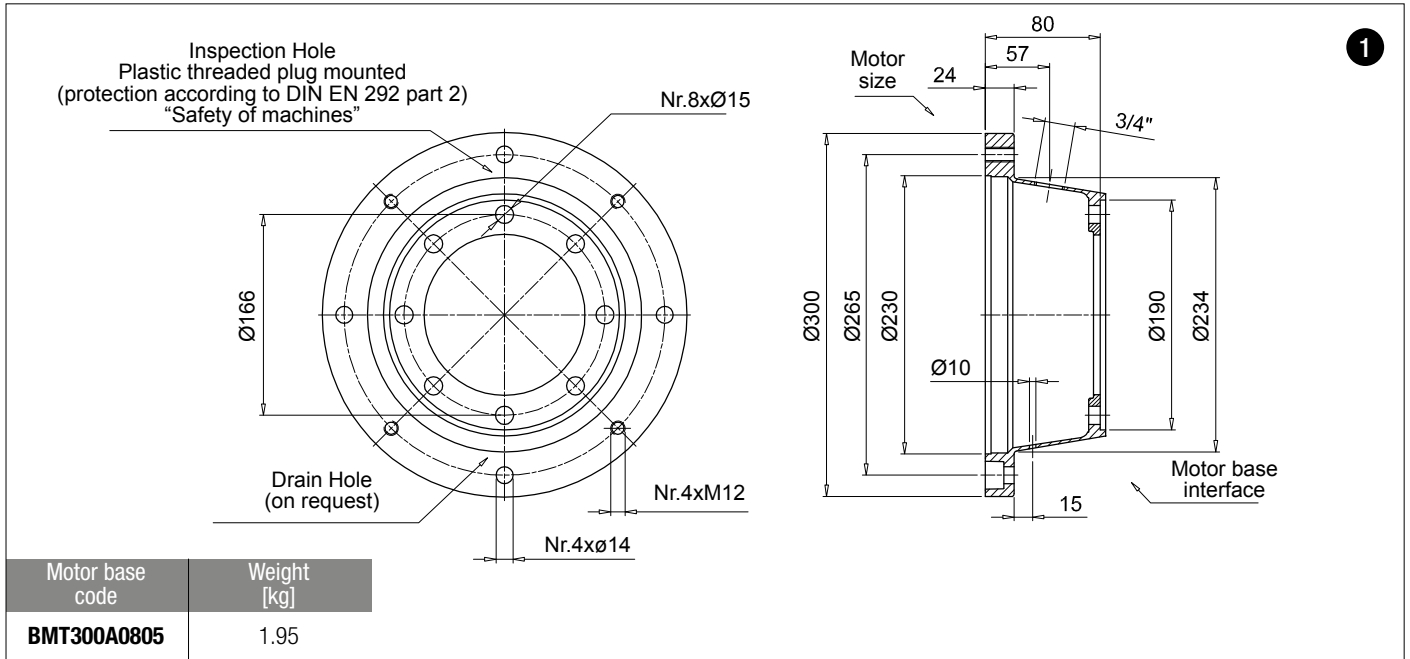

The codes on the chart must be used for dimensional checking only; the ordering codes for all components are available on the on-line software "Power Transmission Software" on the web site www.mpfiltr.com

Pump flange code	H1	Ø1	Ø2	P	Mounting kit	Available pump interface		Weight [kg]
						2 Bolt	4 Bolt	
FP5026***	26	190	170	15	KVG5 See page 111	S023 - D042 - S063 - S070 - S072 S075	S024 - S024 - S033 - S125 - S154	1
FP5032***	32					-	S024 - S031 - S096 - S125	1.1
FP5035***	35					S023 - D042 - S063 - S070 - S072 - S075 - S060 - S072 - S074 - S075 - S106	S021 - S024 - S025 - S026 - S031 - S059 - S068 - S083 - S097 - S125 - S141	0.9
FP5045***	45					S060 - S070 - S071 - S072 - S074 - S075 - S106	S021 - S024 - S025 - S026 - S068 - S125 - S141	0.9
FP5056***	56					S072	S021 - S026	1.6
FP5063***	63					S070 - S079 - S138	S021 - S025 - S068 - S141	1.7
FP5091***	91	-	S025 - S031 - S033 - S113 - S267	2.2				
FP6032***	32	240	218	17	KVG6 See page 111	S081 - S082	S021 - S035	1.8
FP6045***	45					S070 - S075 - S080 - S081 - S082	S021 - S025 - S026 - S027 - S069 - S077 - S125 - S198 - S207 - S215 - S253	2.1
FP6058***	58					S079 - S080 - S081 - S082	S025 - S026 - S027 - S038 - S077 - S078 - S207 - S215 - S237	2.4
FP6070***	70					S080	-	3.0
FP6082***	82					S080 - S081	S038 - S141 - 198 - 215	3.3
FP6086***	86					S090 - S092 - S166 - S091	S021 - S026 - S027 - S077 - S078 - S114 - S132 - 198 - S200	3.4
FP6101***	101					-	S027 - S035 - S113 - S132 - S148 - S176 - S228	4.2
FP6110***	110					S080	S111	5.5
FP7052***	52	288	258	22	KVG7 See page 111	-	S028 - S108 - S112 - S133 - S192	4.4
FP7066***	66					S090 - S092 - S166	-	4.8
FP7069***	69					-	S108 - S143 - S148 - S192 - S201 - S204 - S281 - S282	4.9
FP7086***	86					S091 - S092 - S117 - S166	S022 - S027 - S028 - S108 - S112 - S184 - S192 - S201 - S228 - S300	5.2
FP7111***	111					S091 - S092 - S117 - S145	S028 - S108 - S112 - S133 - S184	6.3

Pump flange code to be complete with available pump interface

Example: **FP6032S021**

Flange interface

Motor base interface

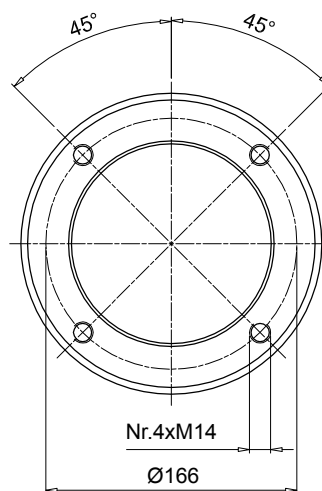
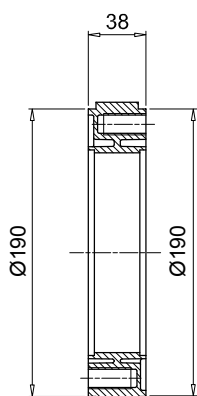
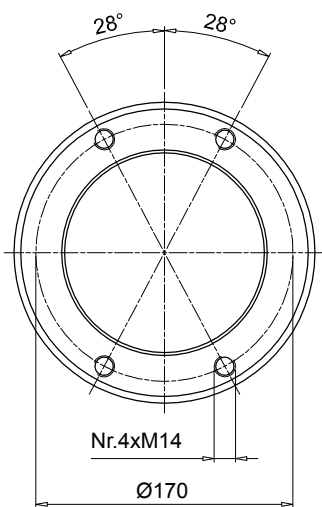

Code	Weight [kg]
AD50385	1.00

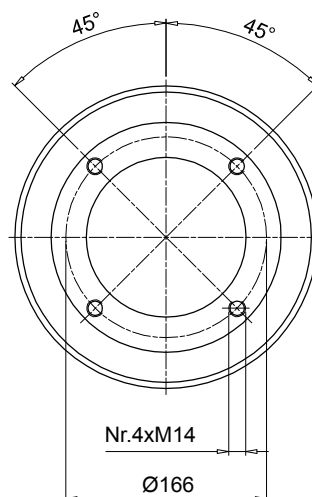
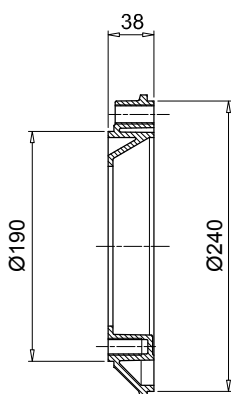
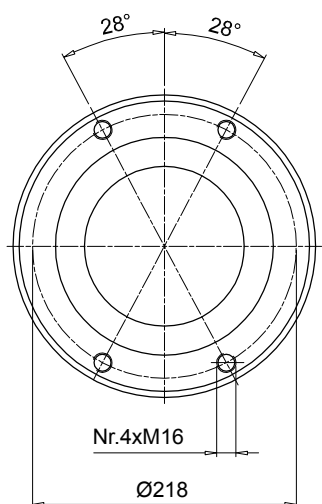

Code	Weight [kg]
AD50386	1.25

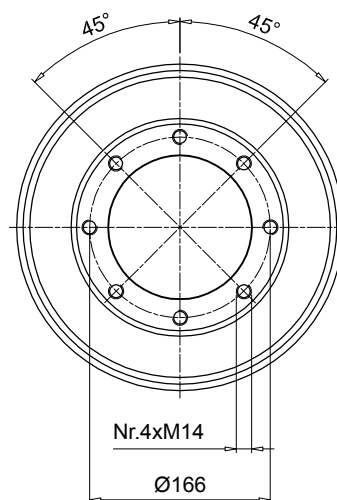
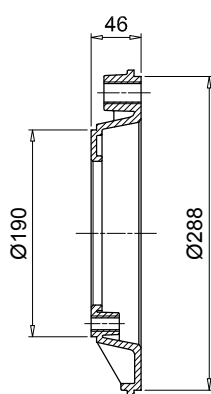
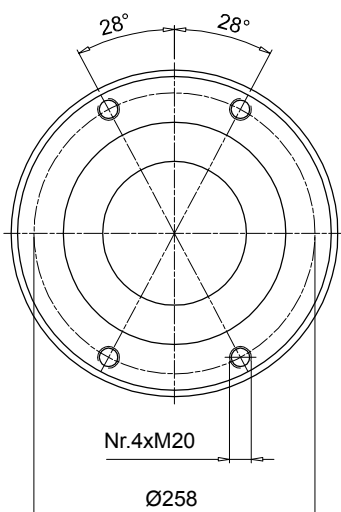

Code	Weight [kg]
AD50467	1.90

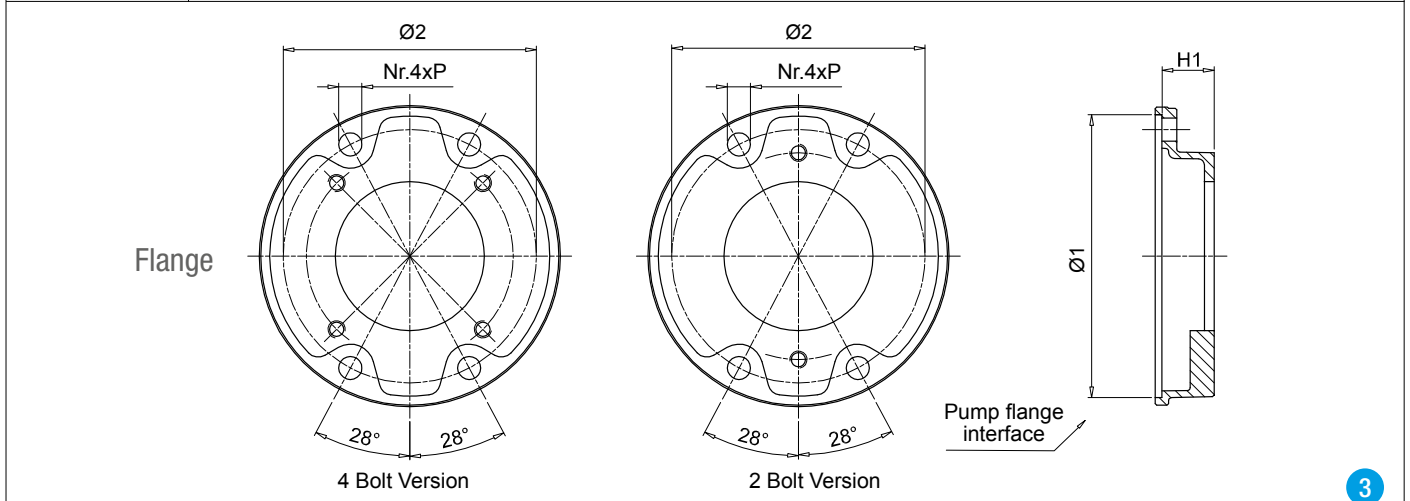
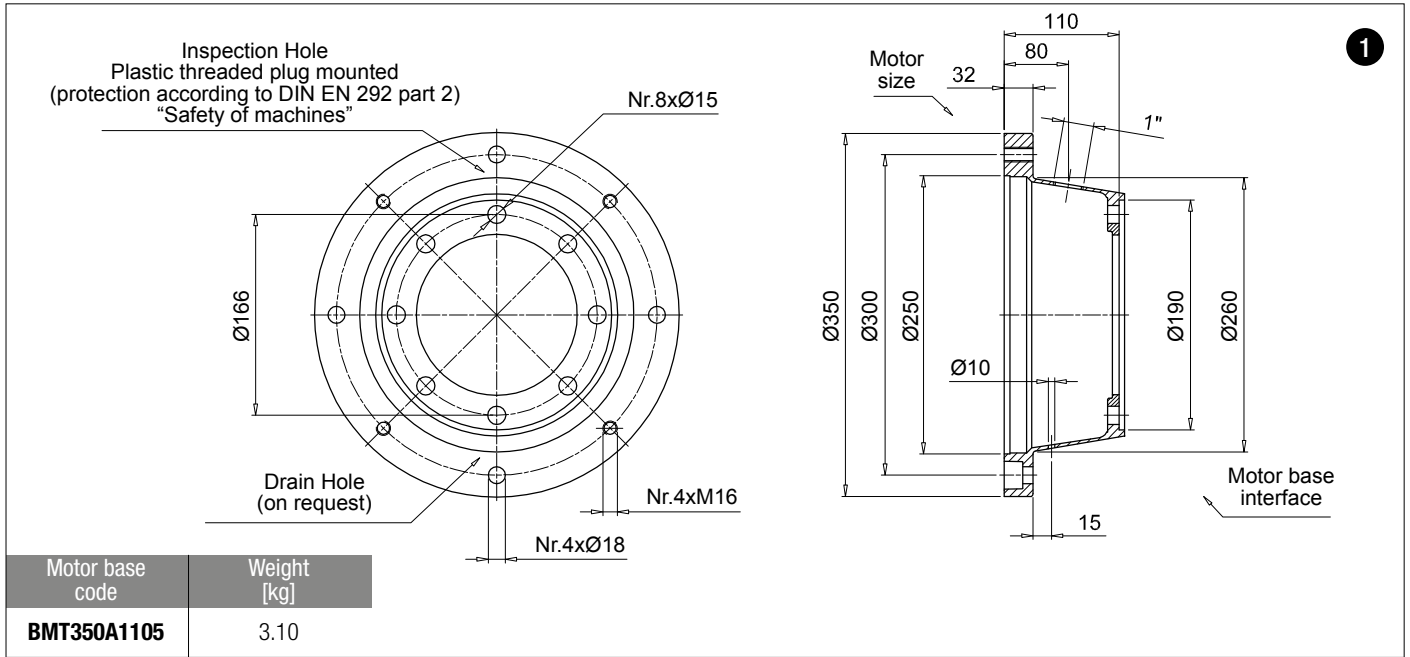

The codes on the chart must be used for dimensional checking only; the ordering codes for all components are available on the on-line software "Power Transmission Software" on the web site www.mpfiltri.com

Pump flange code	H1	Ø1	Ø2	P	Mounting kit	Available pump interface		Weight [kg]
						2 Bolt	4 Bolt	
FP5026***	26				KVG5 See page 111	S023 - D042 - S063 - S070 - S072 S075	S024 - S024 - S033 - S125 - S154	1
FP5032***	32			-		S024 - S031 - S096 - S125	1.1	
FP5035***	35			S023 - D042 - S063 - S070 - S072 - S075 - S060 - S072 - S074 - S075 - S106		S021 - S024 - S025 - S026 - S031 - S059 - S068 - S083 - S097 - S125 - S141	0.9	
FP5045***	45			S060 - S070 - S071 - S072 - S074 - S075 - S106		S021 - S024 - S025 - S026 - S068 - S125 - S141	0.9	
FP5056***	56	190	170	15		S072	S021 - S026	1.6
FP5063***	63					S070 - S079 - S138	S021 - S025 - S068 - S141	1.7
FP5091***	91					-	S025 - S031 - S033 - S113 - S267	2.2
FP6032***	32				KVG6 See page 111	S081 - S082	S021 - S035	1.8
FP6045***	45					S070 - S075 - S080 - S081 - S082	S021 - S025 - S026 - S027 - S069 - S077 - S125 - S198 - S207 - S215 - S253	2.1
FP6058***	58					S079 - S080 - S081 - S082	S025 - S026 - S027 - S038 - S077 - S078 - S207 - S215 - S237	2.4
FP6070***	70					S080	-	3.0
FP6082***	82	240	218	17		S080 - S081	S038 - S141 - 198 - 215	3.3
FP6086***	86					S090 - S092 - S166 - S091	S021 - S026 - S027 - S077 - S078 - S114 - S132 - 198 - S200	3.4
FP6101***	101					-	S027 - S035 - S113 - S132 - S148 - S176 - S228	4.2
FP6110***	110					S080	S111	5.5
FP7052***	52				KVG7 See page 111	-	S028 - S108 - S112 - S133 - S192	4.4
FP7066***	66					S090 - S092 - S166	-	4.8
FP7069***	69	288	258	22		-	S108 - S143 - S148 - S192 - S201 - S204 - S281 - S282	4.9
FP7086***	86					S091 - S092 - S117 - S166	S022 - S027 - S028 - S108 - S112 - S184 - S192 - S201 - S228 - S300	5.2
FP7111***	111					S091 - S092 - S117 - S145	S028 - S108 - S112 - S133 - S184	6.3

Pump flange code to be complete with available pump interface

Example: **FP6032S021**

Flange interface

Motor base interface

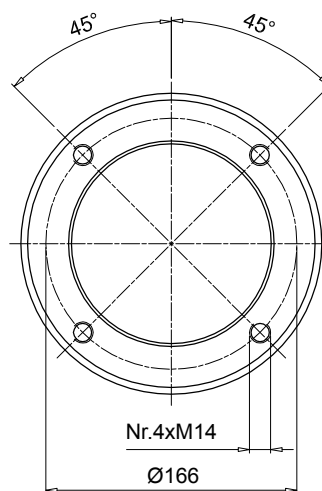
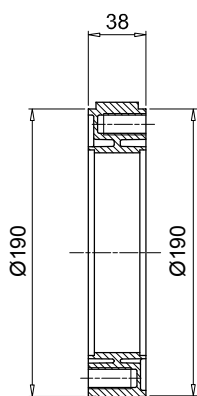
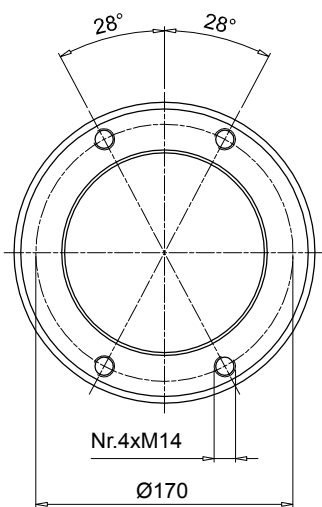

Code	Weight [kg]
AD50385	1.00

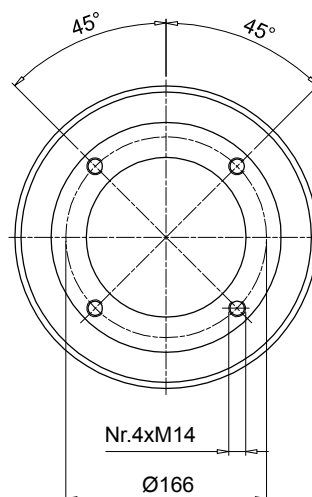
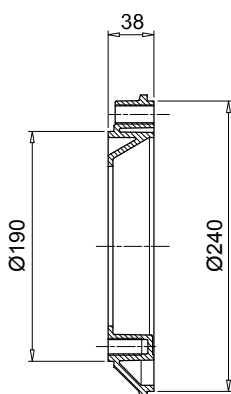
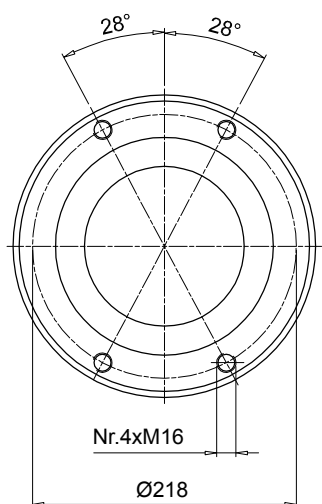

Code	Weight [kg]
AD50386	1.25

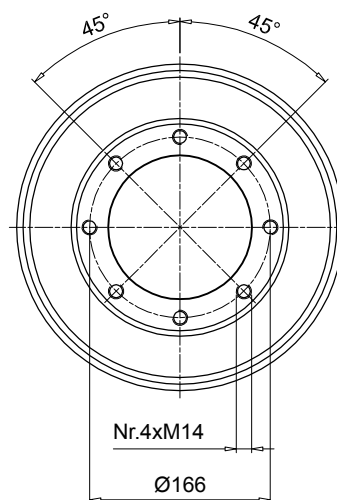
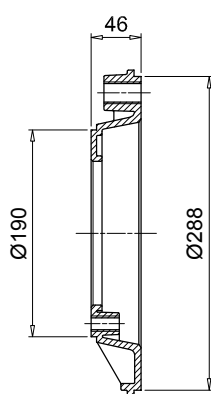
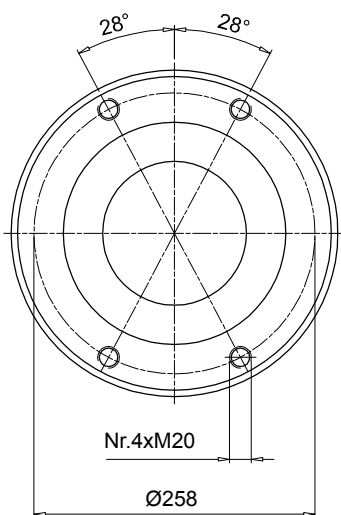

Code	Weight [kg]
AD50467	1.90

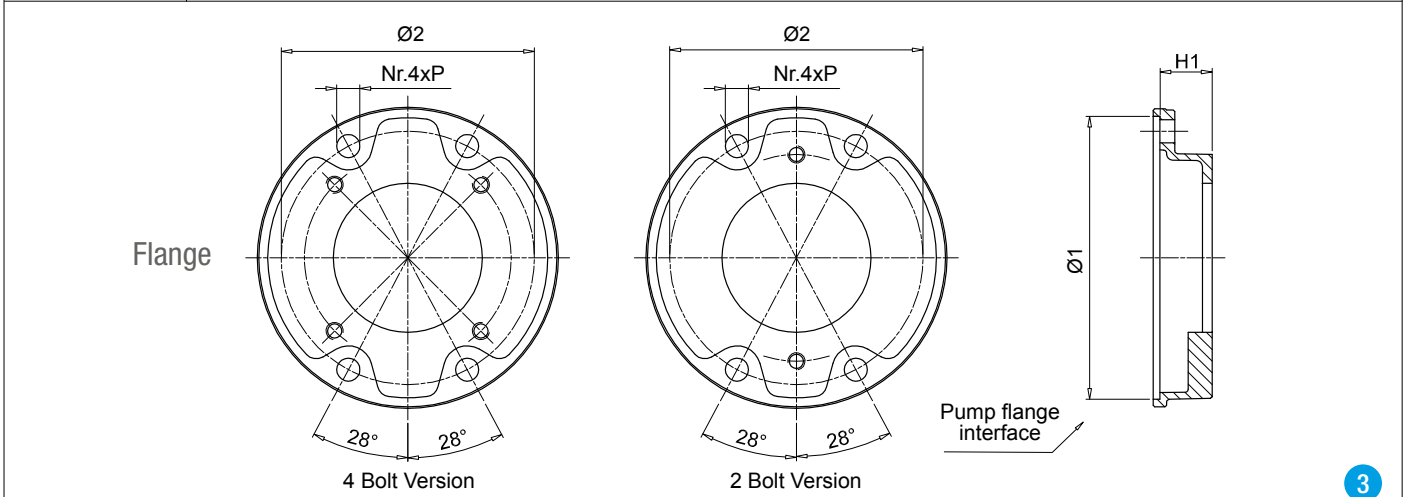
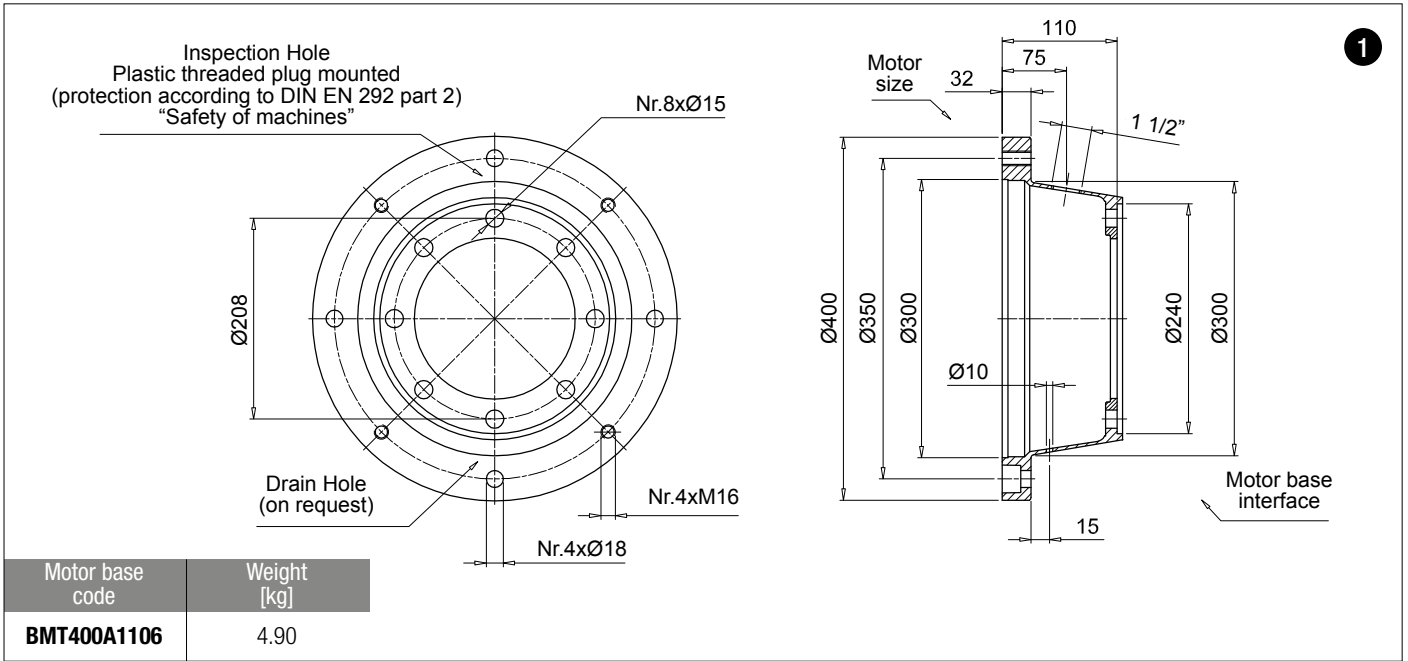

The codes on the chart must be used for dimensional checking only; the ordering codes for all components are available on the on-line software "Power Transmission Software" on the web site www.mpfiltr.com

Pump flange code	H1	Ø1	Ø2	P	Mounting kit	Available pump interface		Weight [kg]
						2 Bolt	4 Bolt	
FP5026***	26				KVG5 See page 111	S023 - D042 - S063 - S070 - S072 S075	S024 - S024 - S033 - S125 - S154	1
FP5032***	32			-		S024 - S031 - S096 - S125	1.1	
FP5035***	35					S023 - D042 - S063 - S070 - S072 - S075 - S060 - S072 - S074 - S075 - S106	S021 - S024 - S025 - S026 - S031 - S059 - S068 - S083 - S097 - S125 - S141	0.9
FP5045***	45					S060 - S070 - S071 - S072 - S074 - S075 - S106	S021 - S024 - S025 - S026 - S068 - S125 - S141	0.9
FP5056***	56	190	170	15		S072	S021 - S026	1.6
FP5063***	63					S070 - S079 - S138	S021 - S025 - S068 - S141	1.7
FP5091***	91					-	S025 - S031 - S033 - S113 - S267	2.2
FP6032***	32				KVG6 See page 111	S081 - S082	S021 - S035	1.8
FP6045***	45					S070 - S075 - S080 - S081 - S082	S021 - S025 - S026 - S027 - S069 - S077 - S125 - S198 - S207 - S215 - S253	2.1
FP6058***	58					S079 - S080 - S081 - S082	S025 - S026 - S027 - S038 - S077 - S078 - S207 - S215 - S237	2.4
FP6070***	70	240	218	17		S080	-	3.0
FP6082***	82					S080 - S081	S038 - S141 - 198 - 215	3.3
FP6086***	86					S090 - S092 - S166 - S091	S021 - S026 - S027 - S077 - S078 - S114 - S132 - 198 - S200	3.4
FP6101***	101					-	S027 - S035 - S113 - S132 - S148 - S176 - S228	4.2
FP6110***	110					S080	S111	5.5
FP7052***	52				KVG7 See page 111	-	S028 - S108 - S112 - S133 - S192	4.4
FP7066***	66					S090 - S092 - S166	-	4.8
FP7069***	69	288	258	22		-	S108 - S143 - S148 - S192 - S201 - S204 - S281 - S282	4.9
FP7086***	86					S091 - S092 - S117 - S166	S022 - S027 - S028 - S108 - S112 - S184 - S192 - S201 - S228 - S300	5.2
FP7111***	111					S091 - S092 - S117 - S145	S028 - S108 - S112 - S133 - S184	6.3

Pump flange code to be complete with available pump interface

Example: **FP6032S021**

Flange interface

Motor base interface

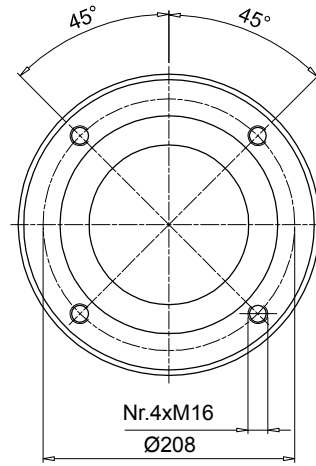
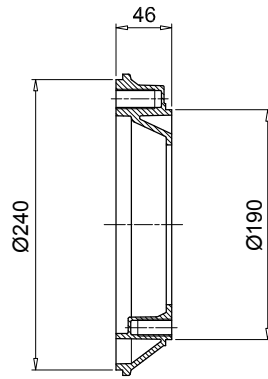
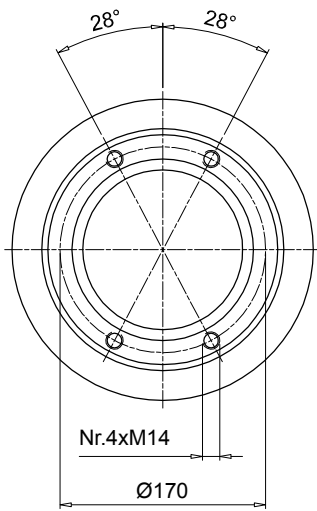

Code	Weight [kg]
AD60465	1.30

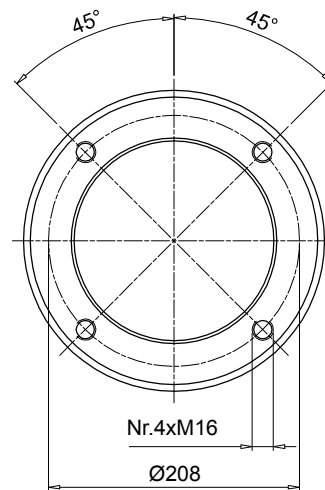
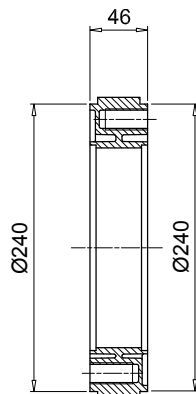
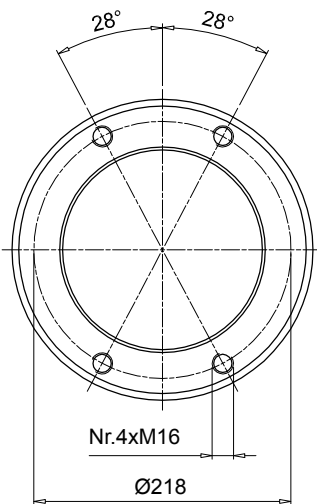

Code	Weight [kg]
AD60466	1.60

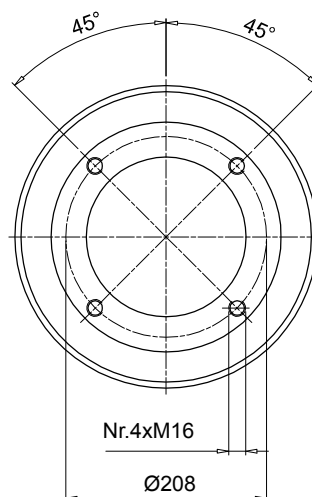
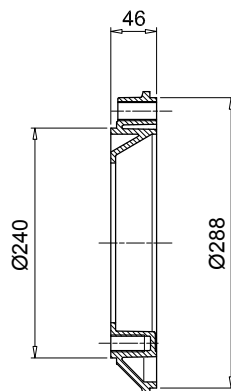
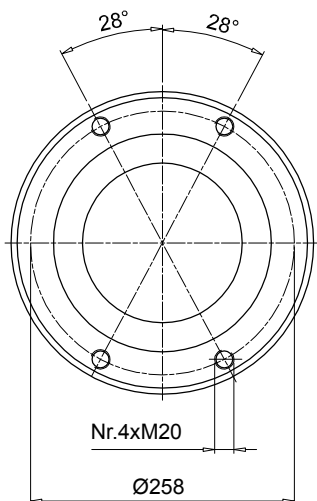

Code	Weight [kg]
AD60467	2.50

Inspection Hole
Plastic threaded plug mounted
(protection according to DIN EN 292 part 2)
"Safety of machines"

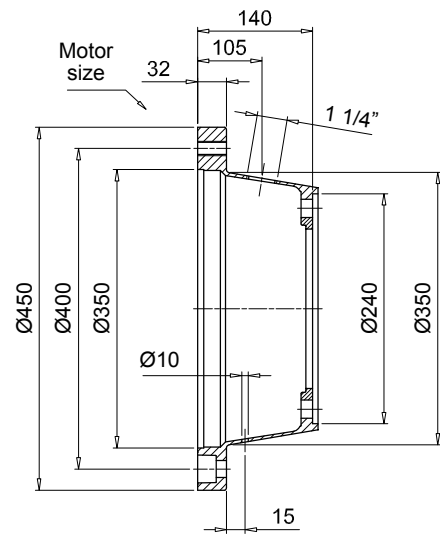
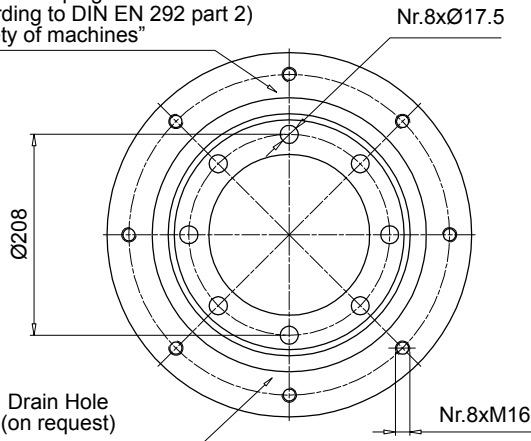

1

Motor base code	Weight [kg]
BMT450A1406	5.00

Flange

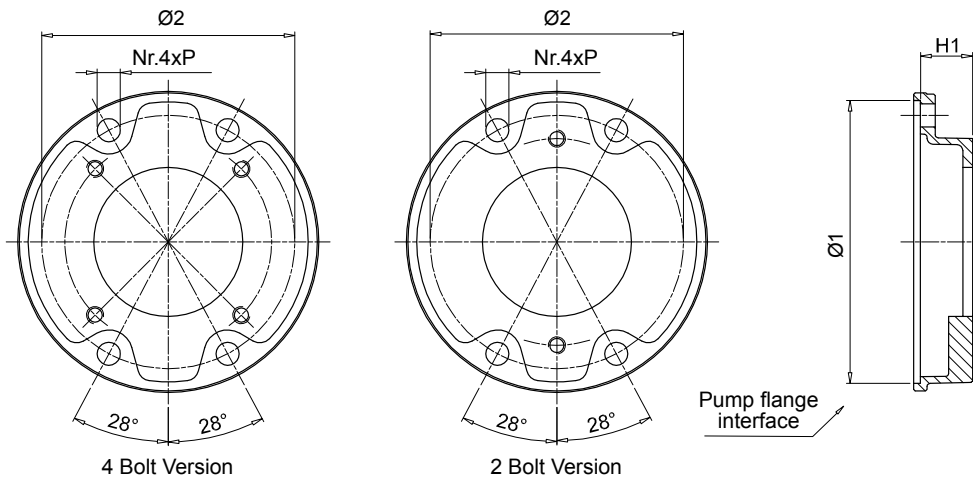

3

The codes on the chart must be used for dimensional checking only; the ordering codes for all components are available on the on-line software "Power Transmission Software" on the web site www.mpfiltr.com

Pump flange code	H1	Ø1	Ø2	P	Mounting kit	Available pump interface		Weight [kg]
						2 Bolt	4 Bolt	
FP5026***	26				KVG5 See page 111	S023 - D042 - S063 - S070 - S072 S075	S024 - S024 - S033 - S125 - S154	1.0
FP5032***	32			-		S024 - S031 - S096 - S125	1.1	
FP5035***	35			S023 - D042 - S063 - S070 - S072 - S075 - S060 - S072 - S074 - S075 - S106		S021 - S024 - S025 - S026 - S031 - S059 - S068 - S083 - S097 - S125 - S141	0.9	
FP5045***	45			S060 - S070 - S071 - S072 - S074 - S075 - S106		S021 - S024 - S025 - S026 - S068 - S125 - S141	0.9	
FP5056***	56	190	170	15		S072	S021 - S026	1.6
FP5063***	63					S070 - S079 - S138	S021 - S025 - S068 - S141	1.7
FP5091***	91					-	S025 - S031 - S033 - S113 - S267	2.2
FP6032***	32				KVG6 See page 111	S081 - S082	S021 - S035	1.8
FP6045***	45			S070 - S075 - S080 - S081 - S082		S021 - S025 - S026 - S027 - S069 - S077 - S125 - S198 - S207 - S215 - S253	2.1	
FP6058***	58			S079 - S080 - S081 - S082		S025 - S026 - S027 - S038 - S077 - S078 - S207 - S215 - S237	2.4	
FP6070***	70	240	218	17		S080	-	3.0
FP6082***	82					S080 - S081	S038 - S141 - 198 - 215	3.3
FP6086***	86					S090 - S092 - S166 - S091	S021 - S026 - S027 - S077 - S078 - S114 - S132 - 198 - S200	3.4
FP6101***	101					-	S027 - S035 - S113 - S132 - S148 - S176 - S228	4.2
FP6110***	110					S080	S111	5.5
FP7052***	52				KVG7 See page 111	-	S028 - S108 - S112 - S133 - S192	4.4
FP7066***	66					S090 - S092 - S166	-	4.8
FP7069***	69	288	258	22		-	S108 - S143 - S148 - S192 - S201 - S204 - S281 - S282	4.9
FP7086***	86					S091 - S092 - S117 - S166	S022 - S027 - S028 - S108 - S112 - S184 - S192 - S201 - S228 - S300	5.2
FP7111***	111					S091 - S092 - S117 - S145	S028 - S108 - S112 - S133 - S184	6.3

Pump flange code to be complete with available pump interface

Example: **FP6032S021**

Flange interface

Motor base interface

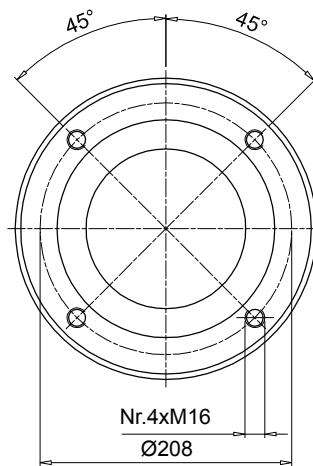
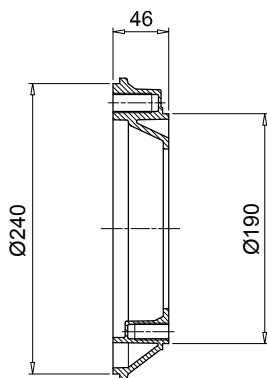
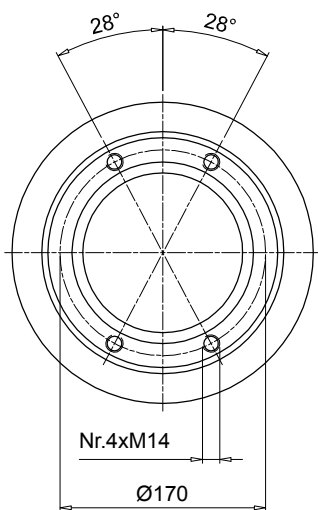

Code	Weight [kg]
AD60465	1.30

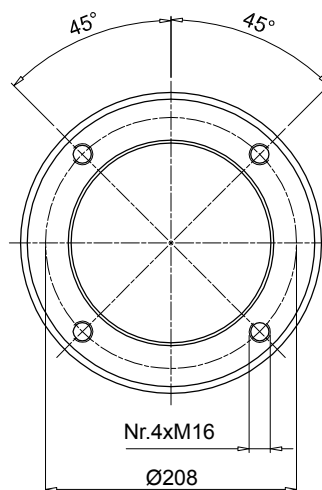
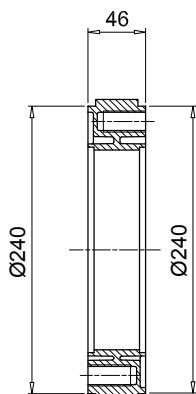
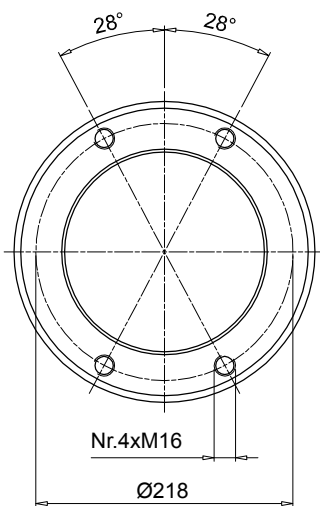

Code	Weight [kg]
AD60466	1.60

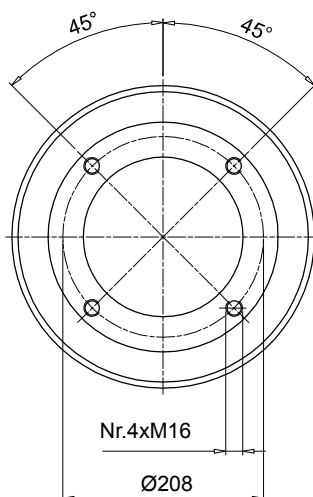
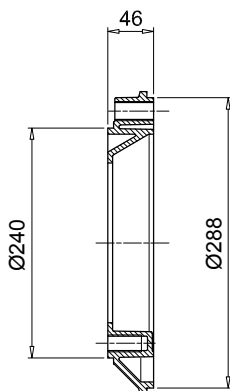
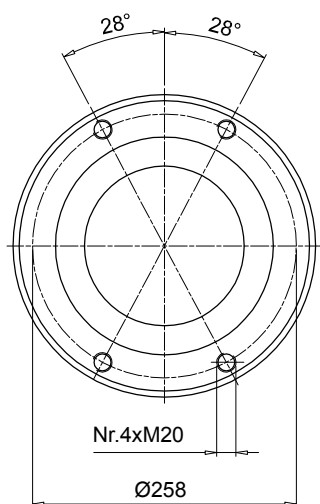

Code	Weight [kg]
AD60467	2.50

1

Inspection Hole
Plastic threaded plug mounted
(protection according
to DIN EN 292 part 2)
"Safety of machines"

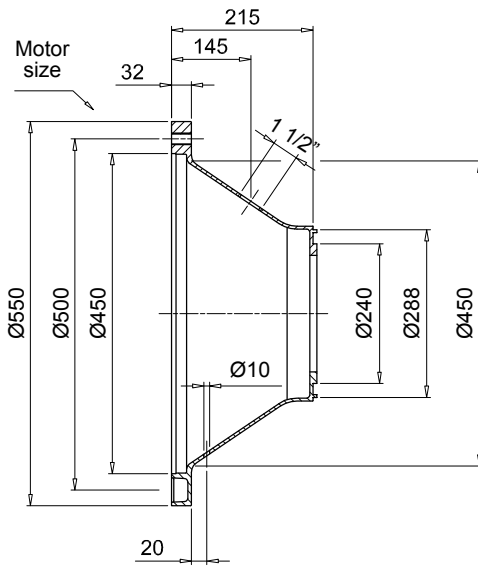
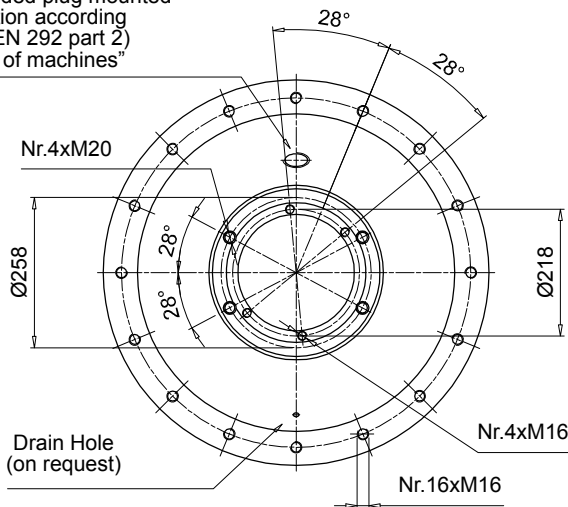

Motor base code	Weight [kg]
BMT550A21567	8.80

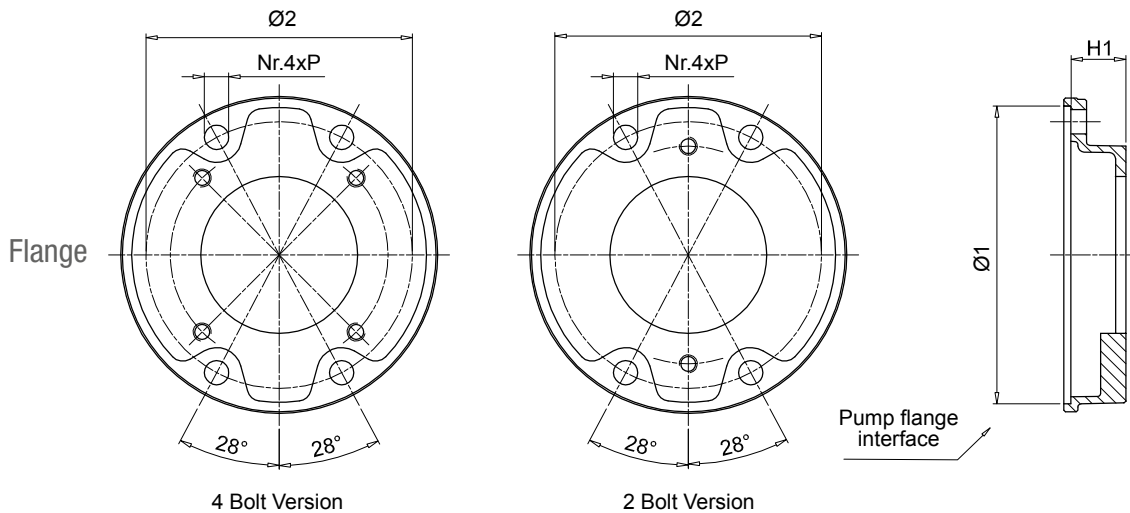

The codes on the chart must be used for dimensional checking only; the ordering codes for all components are available on the on-line software "Power Transmission Software" on the web site www.mpfiltri.com

3

Pump flange code	H1	Ø1	Ø2	P	Mounting kit	Available pump interface		Weight [kg]
						2 Bolt	4 Bolt	
FP6032***	32				KVG6 See page 111	S081 - S082	S021 - S035	1.8
FP6045***	45			S070 - S075 - S080 - S081 - S082		S021 - S025 - S026 - S027 - S069 - S077 - S125 - S198 - S207 - S215 - S253	2.1	
FP6058***	58			S079 - S080 - S081 - S082		S025 - S026 - S027 - S038 - S077 - S078 - S207 - S215 - S237	2.4	
FP6070***	70	240	218	S080		-	3.0	
FP6082***	82			S080 - S081		S038 - S141 - 198 - 215	3.3	
FP6086***	86			S090 - S092 - S166 - S091		S021 - S026 - S027 - S077 - S078 - S114 - S132 - 198 - S200	3.4	
FP6101***	101			-		S027 - S035 - S113 - S132 - S148 - S176 - S228	4.2	
FP6110***	110			S080		S111	5.5	
FP7052***	52				KVG7 See page 111	-	S028 - S108 - S112 - S133 - S192	4.4
FP7066***	66			S090 - S092 - S166		-	4.8	
FP7069***	69	288	258	22		-	S108 - S143 - S148 - S192 - S201 - S204 - S281 - S282	4.9
FP7086***	86			S091 - S092 - S117 - S166		S022 - S027 - S028 - S108 - S112 - S184 - S192 - S201 - S228 - S300	5.2	
FP7111***	111			S091 - S092 - S117 - S145		S028 - S108 - S112 - S133 - S184	6.3	

Pump flange code to be complete with available pump interface

Example: **FP6032S021**

1

Inspection Hole
Plastic threaded plug mounted
(protection according
to DIN EN 292 part 2)
"Safety of machines"

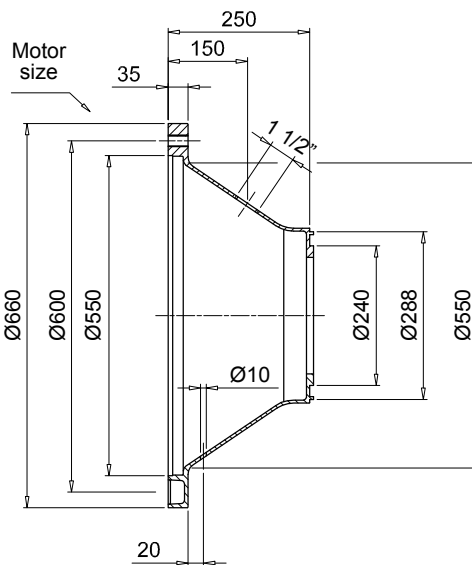
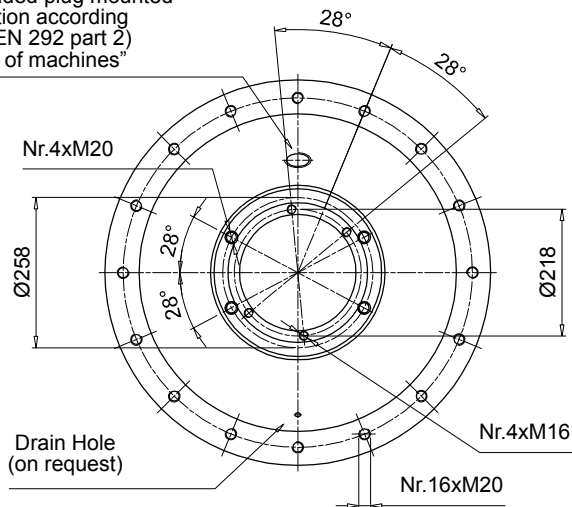

Motor base code	Weight [kg]
BMT660A25067	12.00

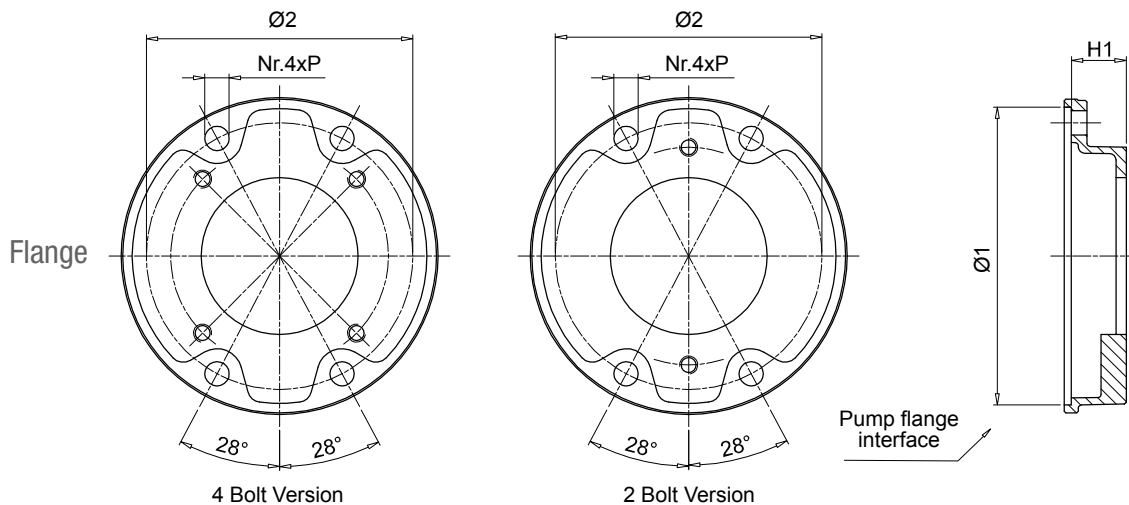

The codes on the chart must be used for dimensional checking only; the ordering codes for all components are available on the on-line software "Power Transmission Software" on the web site www.mpfiltri.com

3

Pump flange code	H1	Ø1	Ø2	P	Mounting kit	Available pump interface		Weight [kg]
						2 Bolt	4 Bolt	
FP6032***	32	240	218	17	KVG6 See page 111	S081 - S082	S021 - S035	1.8
FP6045***	45					S070 - S075 - S080 - S081 - S082	S021 - S025 - S026 - S027 - S069 - S077 - S125 - S198 - S207 - S215 - S253	2.1
FP6058***	58					S079 - S080 - S081 - S082	S025 - S026 - S027 - S038 - S077 - S078 - S207 - S215 - S237	2.4
FP6070***	70					S080	-	3.0
FP6082***	82					S080 - S081	S038 - S141 - 198 - 215	3.3
FP6086***	86					S090 - S092 - S166 - S091	S021 - S026 - S027 - S077 - S078 - S114 - S132 - 198 - S200	3.4
FP6101***	101					-	S027 - S035 - S113 - S132 - S148 - S176 - S228	4.2
FP6110***	110	S080	S111	5.5				
FP7052***	52	288	258	22	KVG7 See page 111	-	S028 - S108 - S112 - S133 - S192	4.4
FP7066***	66					S090 - S092 - S166	-	4.8
FP7069***	69					-	S108 - S143 - S148 - S192 - S201 - S204 - S281 - S282	4.9
FP7086***	86					S091 - S092 - S117 - S166	S022 - S027 - S028 - S108 - S112 - S184 - S192 - S201 - S228 - S300	5.2
FP7111***	111					S091 - S092 - S117 - S145	S028 - S108 - S112 - S133 - S184	6.3

Pump flange code to be complete with available pump interface
Example: **FP6032S021**

1

Inspection Hole
Plastic threaded plug mounted
(protection according to DIN EN 292 part 2)
"Safety of machines"

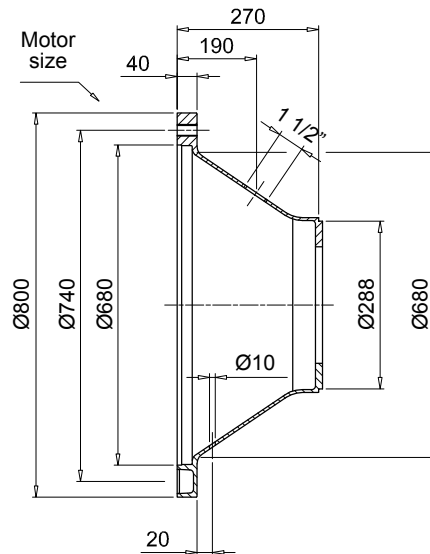
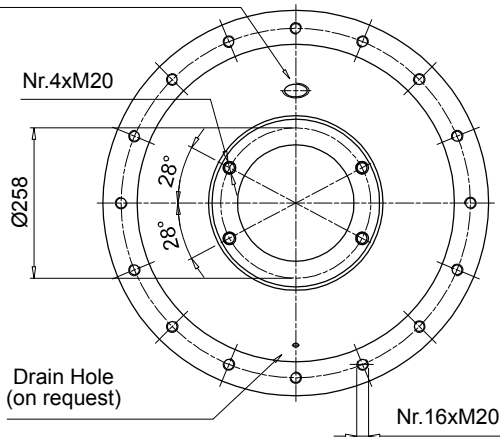

Motor base code	Weight [kg]
BAD800A2707	31.00

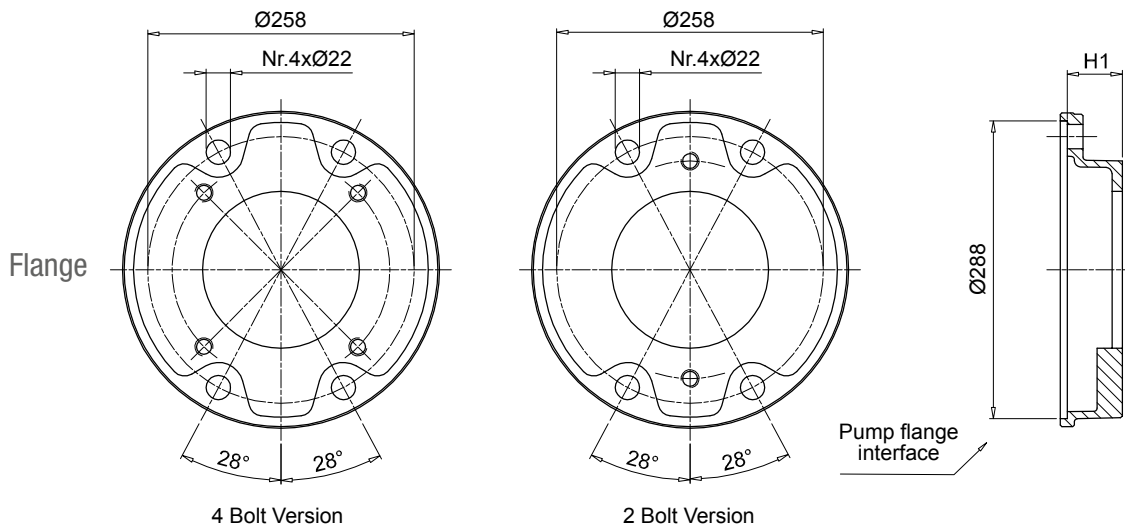

The codes on the chart must be used for dimensional checking only; the ordering codes for all components are available on the on-line software "Power Transmission Software" on the web site www.mpfiltri.com

3

Pump flange code	H1	Ø1	Ø2	P	Mounting kit	Available pump interface		Weight [kg]
						2 Bolt	4 Bolt	
FP7052***	52				KVG7 See page 111	-	S028 - S108 - S112 - S133 - S192	4.4
FP7066***	66					S090 - S092 - S166	-	4.8
FP7069***	69	288	258	22		-	S108 - S143 - S148 - S192 - S201 - S204 - S281 - S282	4.9
FP7086***	86					S091 - S092 - S117 - S166 -	S022 - S027 - S028 - S108 - S112 - S184 - S192 - S201 - S228 - S300	5.2
FP7111***	111					S091 - S092 - S117 - S145	S028 - S108 - S112 - S133 - S184	6.3

Pump flange code to be complete with available pump interface

Example: **FP7052S028**

KVG1

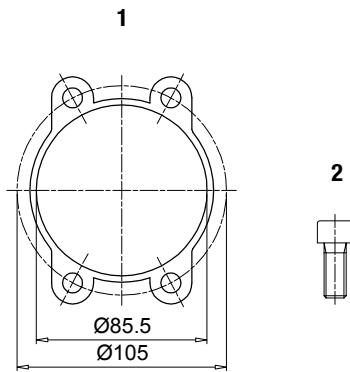

Components				
Item	Description	Q.ty	Material	Torque
1	Gasket for auxiliary flange FR1	1	Paper	-
2	Screw T.C.E.I. M8x20 UNI-5931 8.8	4	Steel	15 Nm

KVG5

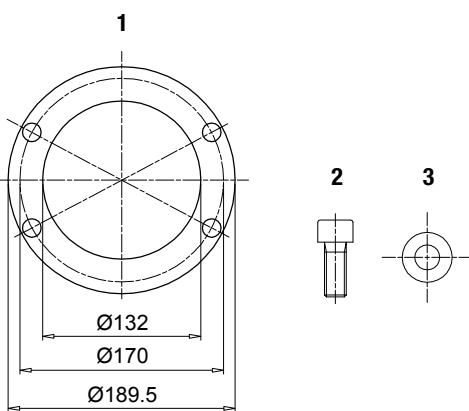

Components				
Item	Description	Q.ty	Material	Torque
1	Gasket for auxiliary flange FP5 / AD5	1	Paper	-
2	Screw T.C.E.I. M14x35 UNI-5931 8.8	4	Steel	90 Nm
3	Washer Schnorr 14	4	Steel	-

KVG6

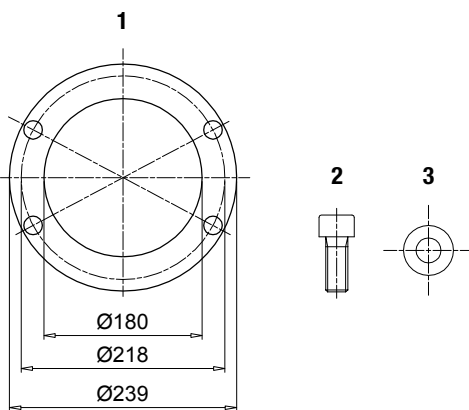

Components				
Item	Description	Q.ty	Material	Torque
1	Gasket for auxiliary flange FP6 / AD6	1	Paper	-
2	Screw T.C.E.I. M16x35 UNI-5931 8.8	4	Steel	130 Nm
3	Washer Schnorr 16	4	Steel	-

KVG7

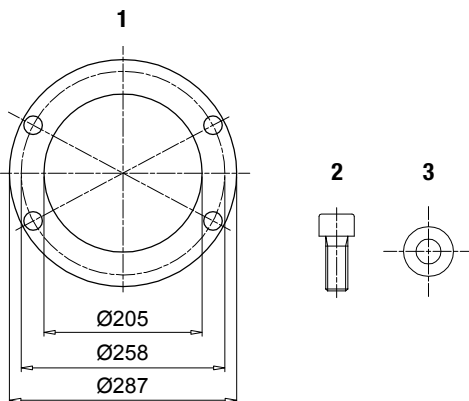

Components				
Item	Description	Q.ty	Material	Torque
1	Gasket for auxiliary flange FP7 / AD7	1	Paper	-
2	Screw T.C.E.I. M20x50 UNI-5931 8.8	4	Steel	200 Nm
3	Washer Schnorr 20	4	Steel	-